

**Manual of Mathematics Teaching Aids for  
Primary Schools**

**Developed with Shri P.K. Srinivasan,  
Mathematics Education Consultant, Madras**



**राष्ट्रीय शैक्षिक अनुसंधान और प्रशिक्षण परिषद्**  
NATIONAL COUNCIL OF EDUCATIONAL RESEARCH AND TRAINING

**Central Institute of Educational Technology  
National Council of Educational Research and  
Training, New Delhi**

## Contents

	FOREWORD	ii
	INTRODUCTION	iii
(I)	Resources for concretising learning process in Mathematics.	1
	UNIT 2. From Number Sense to Number Concept.	3
	UNIT 3. Operations with Whole Numbers.	20
	UNIT 4. Kinds of Numbers and their Properties.	54
	UNIT 5. Basis of Divisibility Rules.	64
	UNIT 6. From Whole to Part or Part to Whole.	69
	UNIT 7. Concepts through practical work for applicability.	112
	UNIT 8. Shapes and Number.	120
	UNIT 9. From Measurement to Mensuration.	138

## Foreword

With the recent technological growth, new methods and materials are being evolved at the formal and non-formal levels of education. Many abstract concepts in Mathematics which the teachers feel difficult to teach the students, could be comprehended with the simple and low-cost teaching aids. Basic concepts, if concretised, through the models and visuals would enrich the experiences of the students for profound creative thought. These models could be devised by the teachers in co-operation with the students and local technology.

Before each aid is introduced in the class, some sort of activity is needed. This could be in the form of cutting strips of paper, collection of seeds or beads or grouping the children. It is necessary to explain the concept to the students and as a reinforcement, the aid may be used with illustrations and examples. Some of the aids given in this Source Manual could be substituted with the ones prepared with the waste and easily accessible materials. Besides models and pieces of apparatus to be used by the teachers, the students should have counterparts of the aids made out of waste materials. In a country where the black-board still continues to be the most fashionable aid and where spending on aids is considered, luxury, improvisation through waste materials like bottle tops, seeds, sparkler rods, bicycle spokes, match sticks, broom sticks, one side impression sheets, square ruled sheets, clay, printing press cuttings (waste), drug store empty card board cartons, thread, wire and empty tins etc., should be increasingly used to prepare aids. Such improvisations will obviate the problems of inventory, stock taking, replacements etc. Our schools suffer heavily due to lack of funds and there is hardly any money with the schools to buy the teaching aids. Through improvisation, each learner can have his/her own kit of aids for ready use in getting understanding and reinforcement. However the improvisation should not be at the cost of quality of aid. Care has to be taken to see that the models prepared for various concepts are functional and dynamic.

Some teaching aids may be taken up as reinforcement; also some of the aids provide enrichment while many aids are mainly for preparatory exercises for the subject matter. A few aids with alternative materials could be taken in the form of experiments and used as a playway activity for checking the authenticity. Some of the models, reflected in the book are already available in some form or the other but the teachers have no easy access. Hence the need to incorporate such aids with illustrations has been emphasised.

The Central Institute of Educational Technology, NCERT has already produced a Manual of 25 aids in Science and Mathematics for the teachers and students of rural primary schools, after conducting a series of programmes on the preparation of low-cost teaching aids for the selected rural primary and upper primary school teachers in the various States of India.

This '*Manual of Mathematics Teaching Aids for Primary Schools*', consisting of suggested aids at the primary school level, is second in the series and has been devised in collaboration with Shri P.K. Srinivasan, the Academic Secretary of

the Association of Mathematics Teachers of India and a Mathematics Education consultant. Each concept is introduced by an aid with its illustration showing step by step construction. The matching write-up of the illustration lists out the objectives, raw materials, processes of preparation and uses/applications. The underlying idea is that the teachers in their own situations could develop the aids by involving their students and the local technology.

I am thankful to Shri P.K. Srinivasan, for the suggestions, he made in the Evaluation Workshop held in Delhi and in carrying out the suggestions at our request, as well as to Kumari P.S. Prasannalakshmi and Sunil Kumar for the art work they did. My thanks are also due to Dr. Harmesh Lal and Shri Arvind Gupta who went through the compilation and got some of the projects field-tested. Dr. Harmesh Lal also laboured hard to co-ordinate and compile this work.

I trust that the work would receive wide acceptance and the primary schools in our country would strive to blossom into nurseries for mathematically competent citizenry.

Dr. M.M. Chaudhri  
Joint Director, CIET

## Introduction

Why learning aids?  
"To see the twinkle in a child's eye".

Mathematics is one of the areas of the school curriculum that makes a great demand on teacher's resourcefulness in creating relevant learning situations for formation of concepts in children's minds. Mere telling without exposing children to learning experiences causes havoc in the learning process. Training children in acquisition of skills through imitative and repetitive exercises continues to be considered respectable as it carries the backing of tradition. Skill is by and large the pay-off of drill in reciting, reading and writing, engendering dependent learning. Even the infants in nursery schools are subjected to this, though it runs counter to their nature. The benefits are seen to be short term with no development of insight into or taste for mathematical thinking.

Recent research findings in different centres of the world bear ample testimony to the need for adoption of strategies that provide children appropriate and adequate experiences for abstracting ideas and finding their way to get at concepts with long term benefits characterised by learning through self-confidence and initiative.

Mathematical concepts grow up in complexity and depth and children can be expected to arrive only if they are helped to be alive to them according to their levels of maturity and attainment. Since mathematics is a highly linked body of knowledge, the start given in primary and pre-primary schools is extremely crucial. *Time has come to judge the worth of an item and clear it for being given a place in the syllabus only after examining its concretisation potentials.*

The child is fascinated by the reality around it and is on an exploration spree right from its birth to find order and meaning in the big booming confusion in which the child finds itself. In this romantic venture the child is guided by its instinct and intuition. Instead of helping the child to continue its efforts in exploration, the teacher is often seen to come between the child and the reality and substitute hasty verbalism and symbolism under the ostensible reason of promoting sheltered learning to pass examinations with the result that the child finds itself blocked and strait-jacketed and has to struggle for access to reality to blossom into an independent learner. As the child climbs up the ladder of mathematical learning, the child finds itself compelled to do artificial if not meaningless things to its utter dismay and disappointment, but many reconcile themselves to the 'way of the world', while a few manage with their extraordinary gift of intuitive strength to thrive on this poor exposure and overcome the resistance that is developed in them to chart their way to success in genuine mathematical learning.

With the advent of the Calculator and the Computer which have removed the drudgery of computation, any lingering excuse for the perpetuation

of teaching methods which promote mere acquisition of skills at the cost of understanding of concepts, gets knocked out. The need to reach all children in their efforts to learn good mathematics is being increasingly realised and demanded, more so when mathematics is introduced right from infant classes.

So the teacher has to rise to the expectation of the awakening society for displaying expertise in teaching children through learning experiences which require making of aids. This Manual attempts to give comprehensive and clear guidelines in achieving this desirable objective.

**Teaching—learning aid is a broadbased term. Blackboards, charts, books etc. are all teaching aids. The teacher is also an aid par excellence. But are they learning aids? Do they give children experience of encounter with the reality? Do children get experiences to learn through self-handling and manipulation? The answer is seen to be by and large in the negative. With the alarming rate of drop-outs and continuing math phobia among the surviving learners, remedial programmes cannot be successful without involvement in concrete experiences.**

With paucity of resources, we cannot afford to go in for commercially produced sophisticated learning aids. Fortunately for mathematics it is not even necessary, relieving thereby the teachers from the irksome responsibilities of inventory keeping and maintenance. This compilation aims to show how a teacher can choose ordinary, cheap and often waste materials in the environment without regard to urban or rural setting and fashion them into very effective learning aids. Preference is given to aids which can be placed in the hands of every child in the class-room and/or which can be improvised by every child. It is of course kept in mind that there should be no special demand on craftsmanship and time consuming improvisation.

This is a compilation for teachers and so teachers are free to choose or modify the aids suggested according to the sociological setting in which they find themselves. In all, there are nine units and the major concepts which are relevant to the primary mathematics are covered in eight units and each unit is divided into five sub-units A, B, C, D and E.

- A: Theme or general objective
- B: Verbal listing of concepts that children have to pick up through experiences
- C: Materials required for improvisation
- D: Setting the materials for learning situation or improvising the materials into learning aids and their uses.
- E: General observations on limitations and caution in the use of aids and range of conceptualisation.

### **An appeal:**

It would be a very welcome measure if the educational authorities could institute *practicals* in mathematics in schools at all levels as is done for science subjects and wherever possible, particularly in training centres, set up mathematics laboratories all over the country. *One has to grow into a junior scientist*

*before one can blossom into a junior mathematician.* The earlier the teachers give up their prejudicial notion that 'good teaching is time consuming and not possible under conditions prevailing in schools in our country' the better and faster it would be in ushering in high standards of learning in our schools and this can be done through special programmes in the mass-media, so that a veritable revolution is brought in teacher-pupil relationship in class rooms.

**SKILLS ARE TAUGHT, CONCEPTS ARE CAUGHT**

## UNIT I

### Resources for Concretising Learning Process in Mathematics

Mathematics is an abstract subject and so it is all the more necessary that learning should begin with concrete situations. It is not enough if concretisation is resorted to only in preprimary and the first year of the primary. It is a pity that once children get familiar with the whole numbers, the rest of mathematics is presented as masquerades of whole numbers through rules and formulae without the children being put in situations which reveal their rationale. For example, consider the way children are taught in traditional classrooms some rules and formulae. To multiply  $\frac{2}{3}$  by  $\frac{5}{7}$  multiply the numerators 2 and 5 write the product as numerator and multiply the denominators 3 and 7 and write the product as denominator to get  $\frac{10}{21}$  a masquerade of

whole numbers and their operations! To multiply  $(-4)$  by  $(-8)$ , put down 'minus into minus' as 'plus' first and then 4 times 8 as 32. Is this not again a masquerade of whole numbers and their operations? To find the area of a rectangle, use the formula length  $\times$  breadth. Is this not yet another instance of the masquerade of whole numbers and their operations? How can the concepts of fractional numbers, integers and area be understood without concretisation?

Children vary in their need for experiences with concrete objects to get at ideas. In other words, when most of the children get readily started and would like to remain in a concrete setting, some reach take off stage earlier. No child should be weaned from the use of concrete objects, while ideas are getting formed in its mind. It is in the nature of children to throw away concrete aids and function at the level of ideas and so the teacher's role is only to help this process. Research shows that through multi-embodiment of ideas, the process can be accelerated. Multi-embodiment demands the use of apparently different situations with a common core of mathematical thought. Among the situations, *the discrete and the continuous should go hand in hand.*

Since children need direct access to the outer reality to build up an inner reality in themselves, representational aids and models are not given preference at the primary stage. Once basic ideas are formed in the minds of children, representational aids take on meaning and become inviting without causing much distortion and confusion. Premature use of representational aids and models is therefore inhibiting and needs to be avoided at the initial stages in learning mathematics.

Learning process in mathematics requires the following stages:

1. Encounter with real concrete materials
2. Use of semi-concrete or semi-abstract apparatus



3. Use of representational aids and pictures
4. Verbalisation
5. Symbolisation
6. Algorithms and formal methods

Oral work should embrace translation of situations into expressions, verbal and symbolic, and vice-versa.

Resources for the aids can be spotted and picked up as and when required from the social and natural environment of children. Some of these can be carried as kit by children along with books and notebooks and the kit will vary from class to class. Maximum use should be made of children and limbs of one's body in fashioning learning situations or aids. A list is made out and given below:

1. Children of the class; body and its limbs
2. Objects of different shapes, sizes, kinds and colours, seeds (white and black beans), sticks, broom sticks, coconut shells, dry coconut leaf mid rib, plantain mid rib, papaya or castor stems: flowers, leaves, bamboo sticks or rods (thin), grains, pebbles, stones, clay.  
Beads, plasticine, office clips, rubber bands, bottle tops, (plastic) bangles, lids, nails, containers—cups, teaspoons, ink bottles, soda bottles and milk bottles, locks, paper strips (printing waste), used stamps, dummy coins and notes, thread, twine, match labels, safety pins, umbrella rods, plastic buckets, balls, cardboard boxes, keys, family photographs,  
Square ruled or check ruled sheets, ruled sheets, graph sheets, graduated rulers, sheets of paper, cardboard pieces, lattice or dot sheets, transparent sheets of paper, clock face models with movable hands, strips with one edge straight and the opposite edge curved, planks with one surface flat and the other surface curved, gummed square strips, square-perforated gummed square sheets, calendar sheets, books.

#### **Minimum equipment:**

Two sets of wooden geometrical shapes, solid and hollow in different sizes.

Sets of wooden cubes in different sizes.

A set of standard metric measures of length, capacity and mass.

Spike abacuses with removable spikes.

A set of real coins and currency notes.

Stop watch, time piece.

Scale balance and spring balance.

#### **Accessories**

Scissors, geometrical instruments, moulds for solids, punching pliers, paste or gum, brown sheets, crayon, pencil, sketch pens, colour pencils, blade, eraser, pencil sharpener.

## UNIT II

### **From Number Sense to Number Concept. (Natural Numbers and Whole Numbers)**

2.1	Forming Sets
2.2	Prenumber concepts
2.3	Numbers one to five
2.4	One more or one less
2.5	Numbers 6 to 9 and counting
2.6	Numerals
2.7	Zero
2.8	Counting forwards from a stage
2.9	Higher unit of ten and counting tens
2.10	Two digit number & counting from one to hundred
2.11	Hundred
2.12	Numbers having three digit numerals
2.13	English names of higher units (optional)
2.14	Place value system in base ten

### 2.1

#### **A. Forming Sets**

- B.** Any objects can be considered together to form a set.  
A set is formed when it is possible to say that a specified object belongs to the set or not.  
An object can belong to different sets according to the characteristic or property considered.
- C.** Objects of different shapes, kinds, sizes, colours, etc.,  
Children of the class.
- D.** Classify given objects according to colour and see sets of objects with the same colour formed.  
Classify given objects into those of the same kind. Continue classification exercise according to shape, size etc., see sets of objects formed.  
Think of a set of flowers. Bring a flower and a leaf. Judge which of them belongs to the set of flowers. Continue this exercise with other sets.  
Classification of children: children coming to school (i) by school bus, (ii) by walk (iii) by cycle etc., form sets. Children identify themselves according to criteria and get themselves listed.
- E.** Vague characteristics like beautiful, rich etc., will not give well defined sets as belongingness will be in doubt.

**A. Prenumber Concepts**

- B.** Given a pair of objects, when one is pointed, the other is not pointed out. (one and the other)

From among many objects, one object can be shown or picked up.

Beside one object, many objects can be placed. (one and many or more than one)

Two collections which match one to one have the same number of objects and which do not match one to one have unequal number of objects.

When two collections of objects are taken, one collection may have more objects or less objects than the other, or as many objects as the other. (more, less, as many as) If two collections have equal number of objects, found by one to one matching removal of some objects from one set to the other set makes the latter greater and the former smaller.

- C.** Objects, hands, fingers, children.
- D.** Children shown one hand and the other hand without the hand being pointed out. When two children are called, one is identified from the other. One object can be picked up first and then many. Out of many objects one can be shown or picked up. Two collections can be compared by inspection and the greater one guessed first and verified later by one to one matching test. If two collections of objects satisfy one to one or object to object matching test, declare that one collection has as many objects as the other.

Children show as many fingers (up to five) as are shown to them in *different* ways and justify by one to one or finger to finger matching.

**A. Numbers 1 to 5***Fig. 2.2-1***2.3**

- B.** Once a model set is fixed up, any number of sets can be formed to match the model set, one to one. A model set and all the sets that match one-to-one with the model set have the same manyness, or in other words, the same number of objects.

There are model sets for any number. Different numbers have different names. The same number of objects can be presented in different designs (showing conservation of number in spacing; upto five, by inspection without counting).

- C.** Objects (buttons, bottle tops, seeds, beads, etc.), square slips of the same size (gummed ones preferable), square ruled sheet (perforated if available), thread, flowers, leaf-clusters, fingers etc. for one to one can be matching set apart.
- D.** Show some fingers (not exceeding five); objects matching the fingers one to one can be set apart.
- A model set of some fingers (starting with two, then four, then three

SHOWING FOUR IN DIFFERENT WAYS

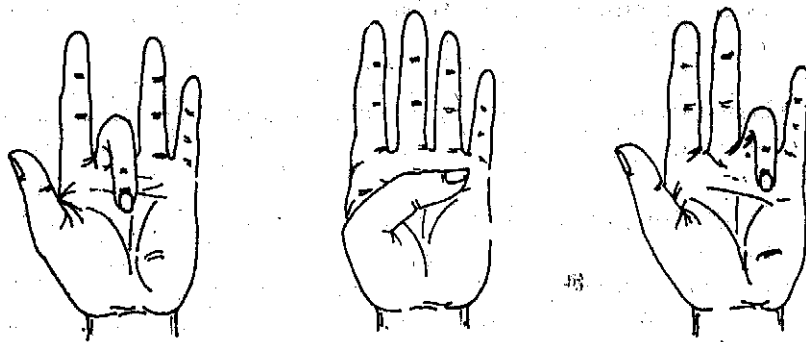

WITH FINGERS OF ONE HAND

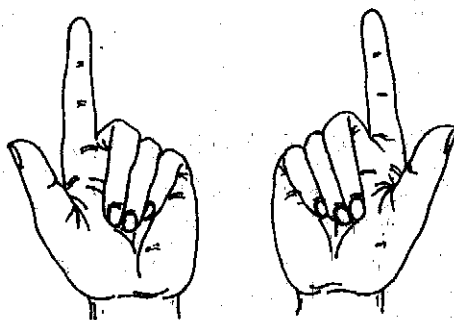

WITH TWO HANDS

*Fig. 2.2.-1*

etc.,) is shown first. Form sets that match the model pair of objects one to one. Each of these sets has two objects. Continue modelling exercise and introduce the other numbers up to 5 in any order.

Thread coloured beads alternately in different (number) patterns like 2 - 3 - 2 - 3 etc.; 4 - 4 - 4 etc.; 3 - 2 - 5 - 3 - 2 - 5 etc. for recognition and identification of numbers.

Shading as many squares as directed with unshaded squares coming in between and stretching as many fingers as directed up to 5 (without counting) are number recognition experiences.

Searching for and picking three leaved, five leaved clusters, etc., from plants and two petalled, four petalled flowers as well secure number recognition (*good homework exercises or tasks*)

**Designing certain number of objects in different ways.** Illustration for designs of five objects. *Fig. 2.3-1*

**Making designs of squares by pasting squares of the same size or by cutting out of a square ruled sheet.**

*Fig. 2.3-2*

Children (numbering from 2 to 5) can make different formations by sitting.

- E.** Instant recognition of numbers up to five is within the competence of children. This skill should not be allowed to atrophy by lack of practice and to the disadvantage of children in differentiating the questions 'how many' (cardinality) from 'which one' (ordinality) in the use of numbers.

## 2.4

### **A. One more or one less (not exceeding five)**

- B.** A number and one more give the next higher or the successor number. A number and one less give the preceding lower or the predecessor number. Every time one more is thought of when a number is given, a new number is got. Two is got by putting one more with one. Three is got by putting one more with two. Four is got by putting one more with three. One is got by making two less by one. Two is got by making three less by one. Three is got by making four less by one

Natural numbers start from one and increase one by one to give one, two, three, four etc.,

- C.** Common objects, fingers, limbs  
**D.** Point out the limbs and give their numbers; five fingers, two ears, two eyes, one nose, etc.

Pick up a certain number of objects (not exceeding five) and consider what should be done to get the next number. One more object is to be

FIVE OBJECTS IN DIFFERENT DESIGNS

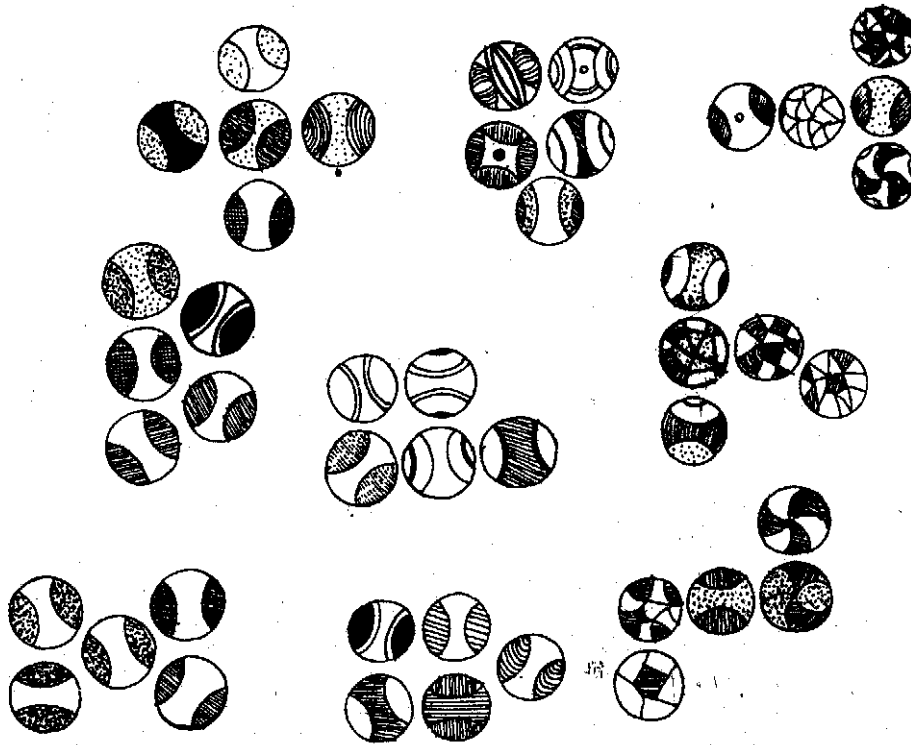

Fig. 2.3-1

FOUR SQUARE DESIGNS

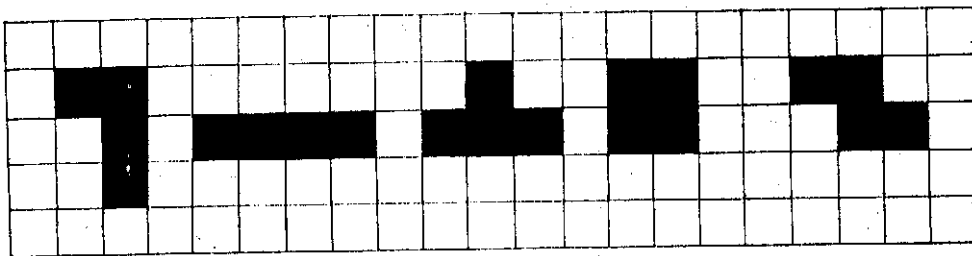

Fig. 2.3-2

taken. Continue this experience with other numbers. Increase one by one and spell out two, three, four  
Recite the numbers one, two, three, four and five.  
Repeat this experience using fingers. Show one finger, say one; raise one more finger, say two; raise one more finger, say three and so on.

2.5

**A. Numbers 6 to 9 and counting**

**B.** New numbers are got by considering one more

Five and one more is six

Six and one more is seven

Seven and one more is eight

Eight and one more is nine

Numbers in order are one, two, three, four,

five, six, seven, eight, nine.

Matching these in order with objects (in any order)

and noting the name that matches the last

object is basic to counting. Number name

matching the last object names the number of objects counted.

**C.** Objects (seeds, beads, sticks, buttons, square paper slips of the same size, fingers).

**D.** Stretch five fingers, put up one more and name the number of fingers stretched as six. Continue this experience till nine is reached.

Make designs for a given number (not exceeding 9) of objects.

Finding the number of objects in a collection by counting (matching one to one number names in order with objects).

2.6

**A. Numerals**

**B.** Numerals are symbols for number names

**C.** Sticks

**D.** Arrange the sticks in such a way the number of objects matches the numeral

*Fig. 2.6-1*

**E.** This is not natural but interesting to help associative memory.

2.7

**A. Zero**

**B.** When there are no objects to count, we say there are zero objects.

When objects are removed one by one from a collection, ultimately zero objects will remain.

When some objects are made and the same objects remain after some time, zero objects are made during the time.

# STICK FIGURES IN NUMERAL ALIGNMENT

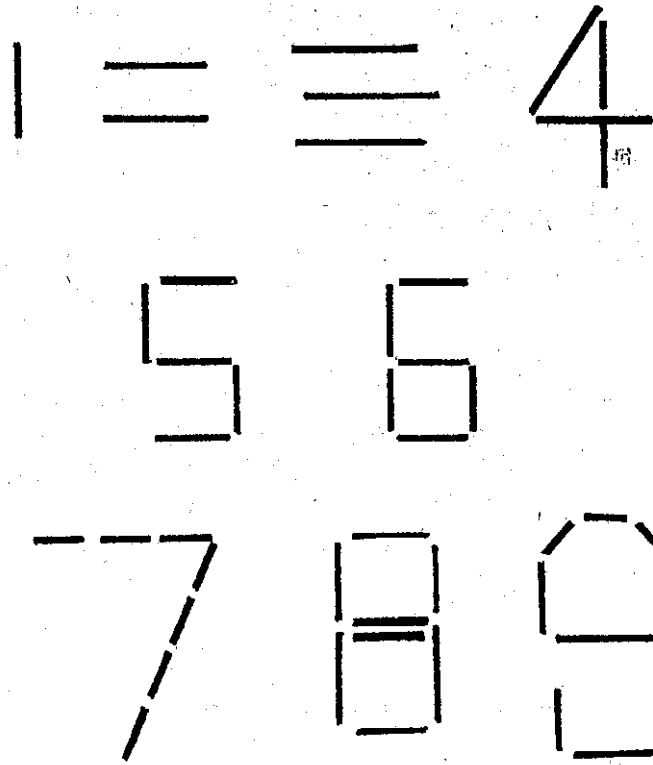

*Fig. 2.6-1*



- C. Family photo, fingers, objects and containers.
- D. When you have no elder brothers, learn to say 'I have zero elder brothers' and so on.

From the photo of a family consisting of father and mother and all their children, one could say that there are zero girls when all the children are boys and zero boys when all the children are girls. Show up your palm with folded fingers. Stretch fingers one by one; count the unstretched fingers and stretched fingers each time. This experience gives practice in saying five unstretched fingers and zero stretched fingers to start with and zero unstretched fingers and five stretched fingers to end up with.

By putting objects in a container, children watch and count them. Put two more and children say two more have been put. Don't put any more. Children say zero objects have been put.

Place some objects in a container. Let children watch and count them. Remove some objects. Children count the objects in the container. Act removing without removing. When the same number of objects are seen in the container, zero objects are removed. When zero objects are in the container, all the objects have been removed.

*Fig. 2.7-1*

**A. Counting forwards from a stage 2.8**

- B. Counting need not always start from one. It can start from any convenient stage.
- C. Materials, fingers.
- D. Take a collection of objects (number not exceeding nine). Set apart two objects and start counting forwards and find the number of the collection. Set apart three objects and start counting forwards and find the number of the collection. Set apart four objects and repeat the experience.

Repeat the experience with fingers as well.

**2.9**

**A. Higher unit of ten and counting tens (upto ten tens)**

- B. Nine and one more is ten  
Ten units make one ten and ten is a higher unit  
one ten is ten; two tens are twenty;  
three tens are thirty and so on.
- C. Sticks (90), thread or rubber bands, Slips of paper (90) (printing paper waste) and office clips.
- D. Sticks are counted in tens and bundles of ten sticks are made by tying each bundle with thread or rubber band.

# ACTIVITY FOR ZERO OBJECTS

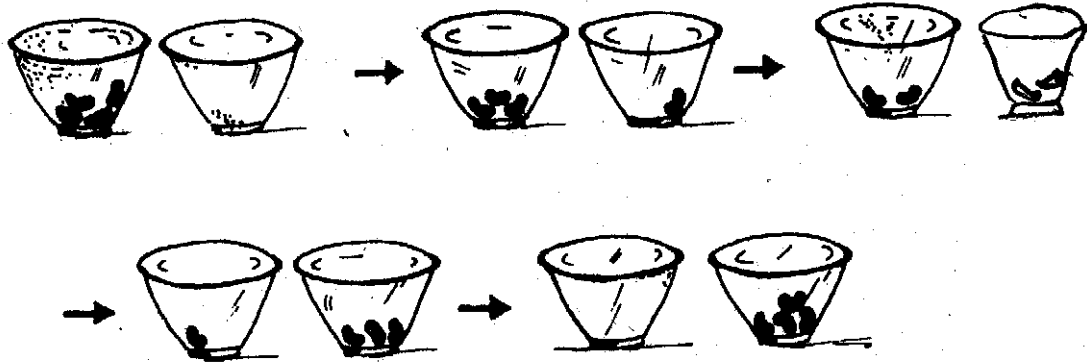

Fig. 2.7-1

Count the bundles of ten sticks and give the number of sticks in the given number of bundles.

Instead of sticks, use slips of paper, count them in tens and clip each bunch of ten slips with an office clip. As before, count a certain number of bunches and give the number of slips in them.

## 2.10

### A. Two digit numbers and counting from one to hundred

**B.** Numbers greater than nine and less than hundred (ten tens) are expressed as two digit numerals.

In counting from one to hundred, there are hundred number names and hundred numerals. The place values of digits in a two digit numeral are respectively tens and ones from the left.

**C.** Sticks (450), loose sticks (9) Paper slips (450), loose sticks (9), Square ruled sheets.

**D.** Get nine ten-stick bundles and nine ten-slip bunches ready.

Make mixed collection of ten stick bundles and loose sticks in the collection as so many tens and ones. Verify by counting and learn to recite from 1 to 99.

Represent two digit numbers by ten-stick bundles and loose sticks.

Repeat the experience with bunches of ten slips and loose slips.

Make nine ten-square slips and nine loose squares. These are more convenient to handle to read and represent numbers in two digit numerals.

Shade squares to show 1 to 99 in square ruled sheets to familiarise yourself fully with counting from 1 to 99.

### A. Hundred.

## 2.11

**B.** Ten tens make one hundred. Hundred ones make one hundred.

~~Hundred ones make one hundred.~~

**C.** Ten-stick bundles (10), ten-slip bunches (10) and ten-square slips (10)

**D.** Count ten-stick bundles as one ten or ten, two tens or twenty, etc. and learn to say hundred when ten tens are got.

Repeat the experience with ten slip bunches and ten square slips.

*Fig. 2.11-1*

## 2.12

### A. Numbers having three digit numerals

**B.** Numbers greater than ninety nine and less than thousand are represented by three digit numerals.

The place values of the three digits in a three digit numeral from the left are respectively hundreds, tens and ones.

# BUNDLES AND BUNCHES



10

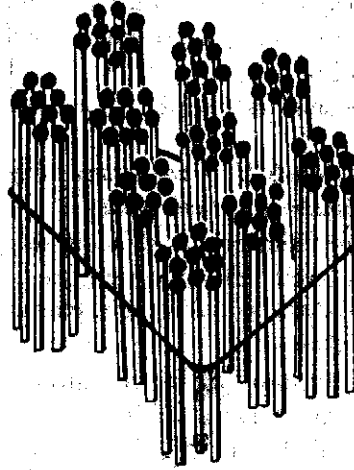

100

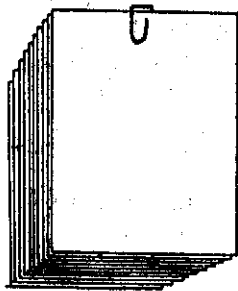

10

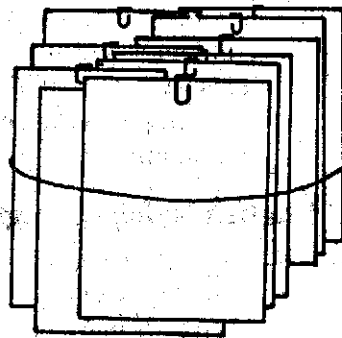

100

*Fig. 2.11-1*

- C.** Ten ten-stick or hundred stick bundles (9) ten-stick bundles (10), loose sticks (10), Ten ten-slip or hundred slip bunches (9) ten-slip bunches (10), loose slips (10) Ten ten-square sheets or hundred square sheets (9), ten square slips (10). Loose square slips (10).
- D.** Make a mixed collection of hundred stick bundles, ten stick-bundles and loose sticks, count and read and record the number of sticks in the collection under the heads H (hundreds), T (tens), and U (units). Represent number in three digit numerals by means of hundred-stick bundles, ten-stick bundles and loose sticks. Note that when there are zero tens and/or zero units, 0 will be recorded under T and/or U. Instead of bundles of sticks, hundred slip bunches, ten slip bunches and loose square slips can be used for the same experience.

*Drop the heads H, T and U and recognise the value of each place to get place value notation across your mind.*

Three children stand facing the class holding up their hands with fingers stretched, showing little finger to little finger. The children represent respectively ones, tens and hundreds from the right of their facing class.

The child standing to the right of the class *i.e.* *ones child* folds fingers one by one starting with her right left finger. When *ones child* finishes folding all her ten fingers, the child to her right (the child in the middle here) or the *tens child* folds one finger, her right little finger. At once *ones child* stretches out all her fingers as one ten has been recorded by the *tens child*. As *ones child* goes on and completes folding all her fingers, *tens child* folds one more finger and *ones child* stretches out all her fingers. When the *tens child* folds all her fingers, the *hundreds child* folds one finger.

This can go on till the *hundreds child* folds all her nine fingers.

At any stage, three digit number is read. Representation of a three digit number by three children can also be done. *Fig. 2.12-1*

### **A. English Names of higher units (optional)**

**2.13**

- B.** There is a spatial basis in the English names of higher units in base ten place value numeration.
- Ten ones make one ten—a *long*  
 Ten *longs* make one hundred—a *flat*  
 Ten *flats* make one thousand—a *block*  
 Ten *blocks* make one ten thousand—a *Long*  
 Ten *Longs* make one hundred thousand—a *Flat*  
 Ten *Flats* make one thousand thousand or million—a *Block*.
- C.** Cm wooden cubes (1000)  
 marked wooden cubes (with faces marked  $10 \times 10 \times 10$ —mm wise) (1000).
- D.** Arrange ten cubes to make a *long* to represent ten.

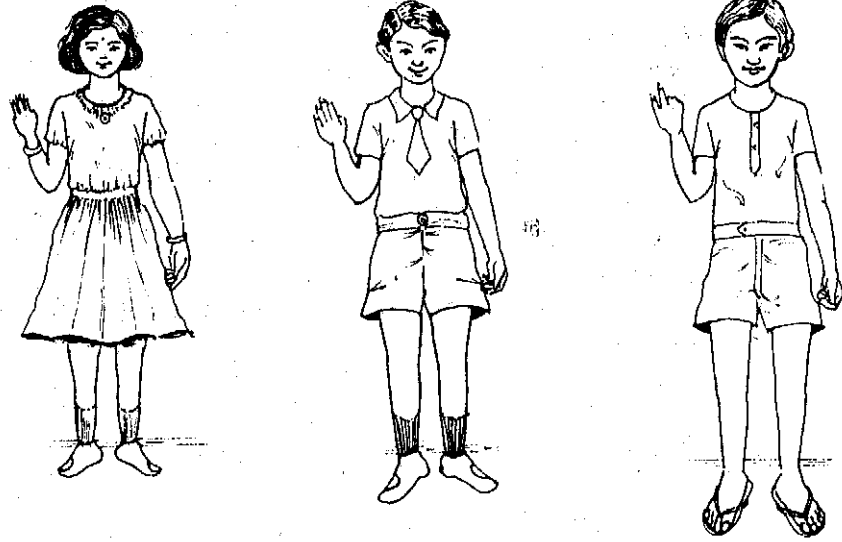

PUPILS ACTING PLACE VALUES AND SHOWING 3 4 2

*Fig. 2.12-1*

Arrange ten *longs* to make a *flat* to represent hundred.  
 Arrange ten *flats* to make a *block* to represent thousand.  
 Using a thousand piece showing marked *cubes*,  
 visualise repeating the above developing process and get the names  
 ten thousand, hundred thousand and thousand thousand or million.

Fig. 2.13-1

2.14

**A. Place value system in base ten**

- B.** Numbers more than nine and less than hundred are represented by two digit numerals. Numbers more than ninety nine and less than thousand are represented by three digit numerals and so on. Each digit has natural value and place value in a multi digit numeral. The place values from the right end are respectively *units, tens, hundreds, thousands, ten thousands, hundred thousands* or *lakhs, thousand thousands* or *ten lakhs or millions, hundred lakhs* or *crores* or *ten millions* and so on. In the (denary) place value system, the value of each place is ten times the value of the place to its immediate right.
- C.** Wooden base, rods, beads or centrally *holed* bottle-tops, plantain midrib, broom sticks and castor stem rings got by cross sectional cuttings; mid rib of dry coconut leaf, bamboo sticks and papaya stem rings got by cross sectional cuttings.
- D.** Improvise a spike abacus. The place values of spikes from the right end are respectively ones, tens, hundreds, etc. No spike can have more than nine objects. Every time ten objects get placed in a spike, they are removed and one object is placed in the spike to the immediate left to represent the ten removed objects.

Fig. 2.14-1

The numbers represented are recorded under heads and their number names read.

<i>Representation</i>	T U	<i>Number</i>
Three tens	3 0	Thirty
Four hundreds five ones	H T U 4 0 5	Four hundred five
Six hundreds seven tens	6 7 0	Six hundred seventy
One thousand four tens eight ones	Th H T U 1 0 4 8	One thousand forty eight

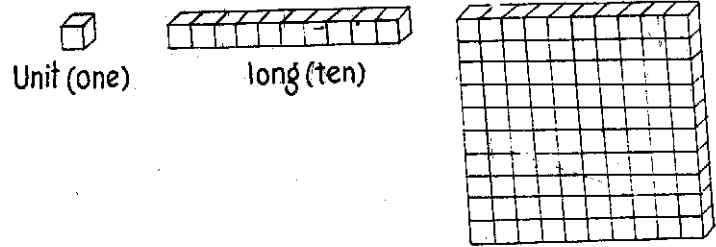

Unit (one)

long (ten)

Flat (ten tens or a hundred)

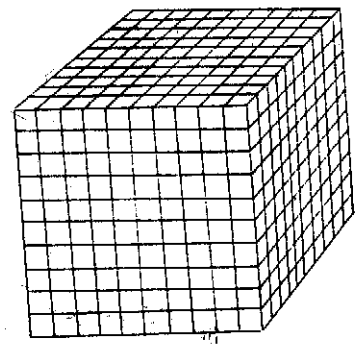

Block (ten ten-tens or a thousand)

Fig. 2.13-1

### IMPROVISED ABACUS

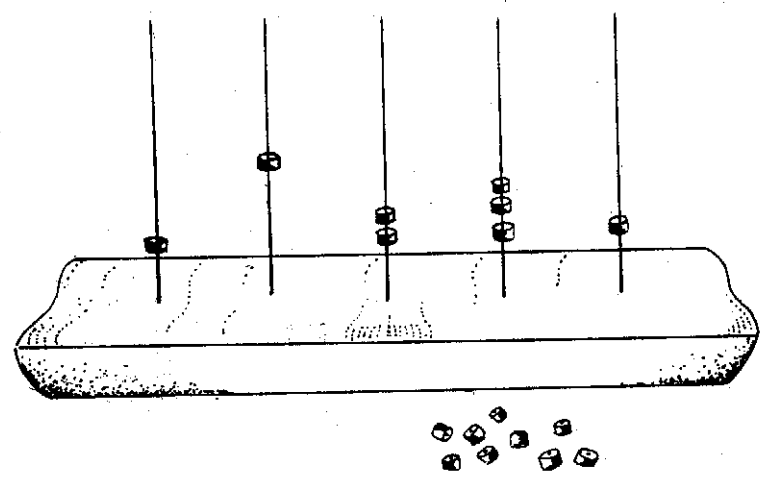

Fig. 2.14-1



NUMBER REPRESENTATION ON A SPIKE  
ABACUS

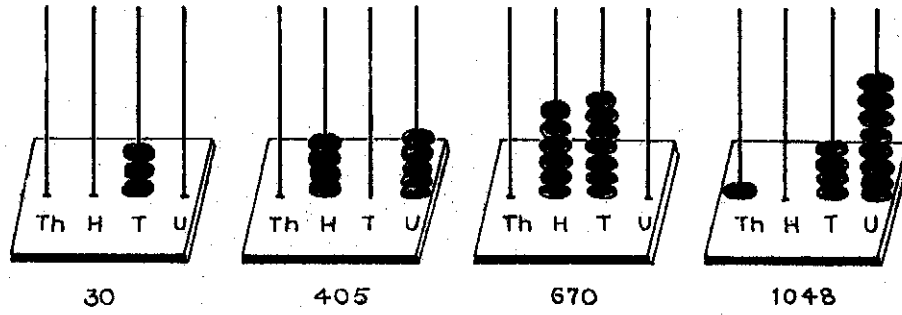

Fig. 2.14-2

SQUARE COLUMN PAPER ABACUS

*Great!*

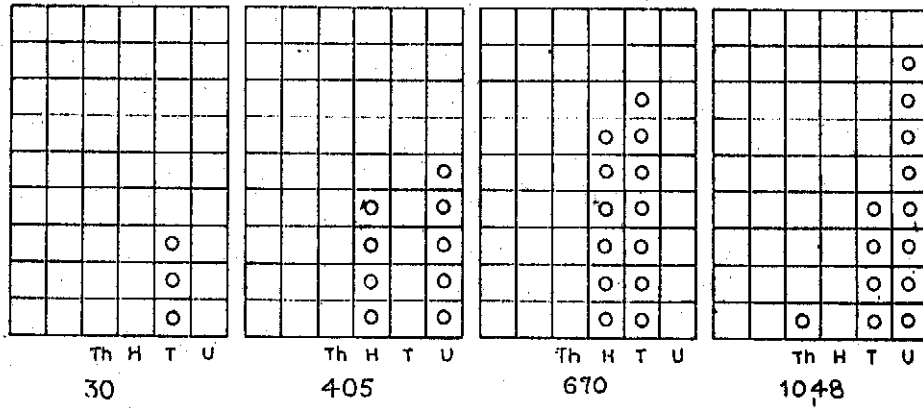

Fig. 2.14-3

Remove the heads and identify the places and give their values. Extend this experience to five digit numbers and check if children have reached the take off stage when visualisation and imagination should take over and aids get dropped.

For convenience, use instead a multi-square-column in a square ruled sheet or slate instead of spike abacus and use dots instead of beads, and use pencil and eraser if paper is chosen or chalk and a piece of cloth if slate is chosen. *Fig. 2.14-3*

- E. Watch for children not considering a multi-digit number as a single number. Check and correct if children take a multi-digit number as a sequence of single digit numbers.

## UNIT III

### Operations with Whole Numbers

- 3.1 Meaning of addition
- 3.2 Basic addition facts, properties and tables
- 3.3 Complementary addition facts
- 3.4 Addition algorithm or process
- 3.5 Comparison of numbers
- 3.6 Meaning of subtraction
- 3.7 Subtraction algorithm or process
- 3.8 Relations between addition and subtraction
- 3.9 Skip counting and repeated addition
- 3.10 Meaning of multiplication
- 3.11 Basic multiplication facts, properties and tables
- 3.12 Multiplication algorithm or process
- 3.13 Meaning of division
- 3.14 Division algorithm or process
- 3.15 Relations between multiplication and division

#### 3.1

##### A. Meaning of addition

- B. Two (or more) collections of objects can be *combined* to form a bigger collection of objects (the two collections having no common objects).  
The number of the combined collection is the sum or total of the numbers of the collections.  
When a collection of objects is *increased* by taking along a certain number of objects, the number of the increased collection is got by adding the number of the collection to the number of objects by which the collection is increased.
- C. Common objects (bottle tops, seeds, buttons, pebbles), bundles of sticks.
- D. Make a collection of objects (number not exceeding 5 to start with).  
Make another collection of objects (not exceeding 5 to start with).  
Combine them. Count the numbers of objects in the two collections and the number of objects in the combined collection. Observe it to be equal to the sum of the numbers of the collections.  
Write the addition fact.  
Make a collection of objects (not exceeding 5 to start with). Increase the collection by adding a few more objects (not exceeding 5 to start with) and find the number of objects in the increased collection.  
Observe that the number of the increased collection is the number of

the collection added to the number of objects by which the collection is increased. Write the addition fact. *Fig. 3.1-1*

E. Note that objects in a collection may be bundles.

3.2

### A. Basic addition facts, properties and tables

B. When *two* single digit numbers are added, the sum is either a single digit number or a two digit number with 1 appearing *always* as the tens place digit if it occurs. The successor of a number is 1 more than the number. This is an addition fact of 1. Addition of units and addition of higher units are alike.

When zero is added to a number, the sum is equal to the number. This is an addition fact of zero.

Two and more than two numbers can be added in any order. Addition facts involving two numbers taken from the digits 0 to 9 are one hundred (Of them there 19 zero-addition facts and 19 one-addition facts. By rearrangement property 45 facts can be got from other addition facts).

C. Fingers, ten square slips, pairs of square slips each having one, two, three etc. to nine squares, a pair of graduated rulers.

D. Use fingers of both the hands for getting addition facts of single digit numbers, the sum not exceeding 9 is got by counting from 1 or counting from one of the addends. *Fig. 3.2-1*

Some addition facts of 0 and some addition facts of 1 can be obtained respectively by not stretching any finger on one hand and by stretching only one finger on one hand.

For adding any two single digit numbers, use a ten square slip and single digit slip, the sum can be got by 'counting forwards' principle.

*Fig. 3.2-2*

A pair of graduated rulers can be used to find the sum of two single digit numbers. Keep one ruler fixed. Bring the zero of the other sliding ruler below the number to be added to (say 2) on the fixed ruler. This gives a series of addition facts (for 2 here). Slide the ruler to move 0 to lie below the next number to be added and lying on the fixed ruler. Stopping ultimately with putting 0 of sliding ruler below 9 of the fixed ruler, all the basic addition facts are read. *Fig. 3.2-3*

Record these facts in the form of a square table and observe the repetition of sums and account for them by rearrangement property.

Addition facts of 0 can be read off by putting 0 of the sliding ruler below the zero of the fixed ruler.

Addition facts of 1 can be read off by putting 0 of the sliding ruler below 1 of the fixed ruler. Record the basic addition facts of single digit numbers 0 to 9.

ADDITION TABLE TWO WITH OBJECTS

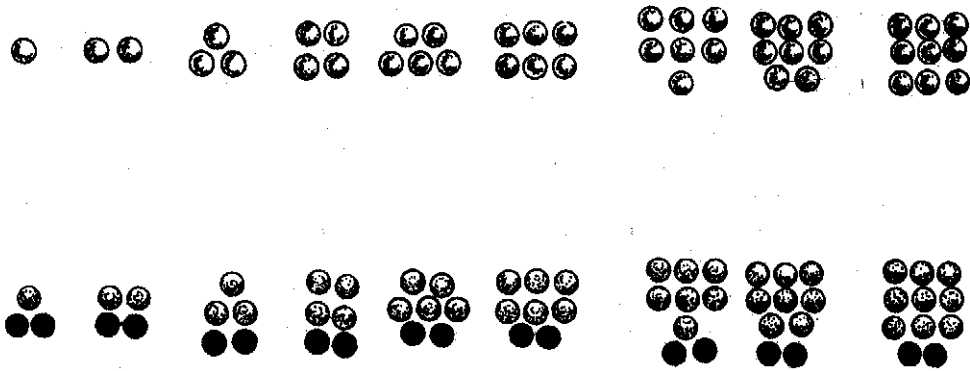

$1 + 2 = 3$ ,  $2 + 2 = 4$ ,  $3 + 2 = 5$  and so on

*Fig. 3.1-1*

33

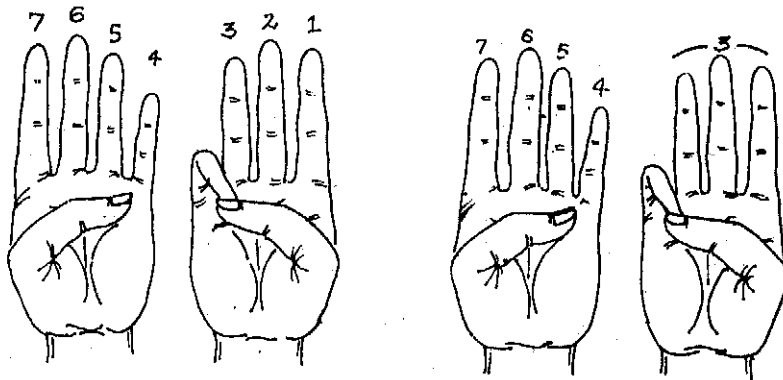

SINGLE DIGIT SUM - ADDITION

WITH FINGERS

*Fig. 3.2-1*

ADDITION GIVING TWO DIGIT SUMS

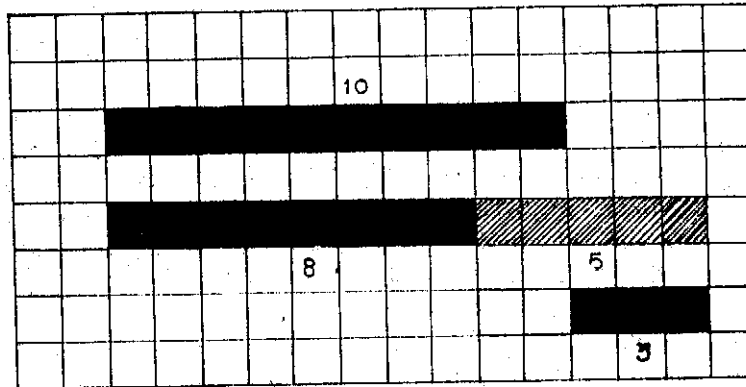
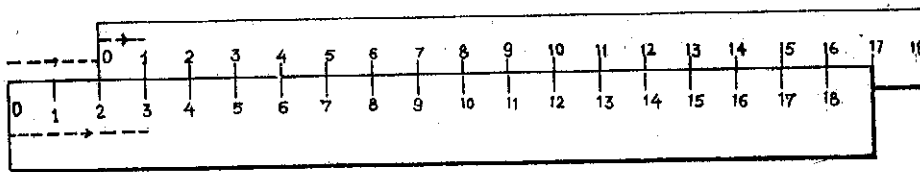

Fig. 3.2-2

ADDITION SLIDE RULE WITH TWO GRADUATED RULERS



$2 + 1 = 3, 2 + 2 = 4$  and so on

Fig. 3.2-3

**A. Complementary addition facts**

- B.** A whole number can be given as a sum of two whole numbers. Such addition facts are the complementary facts of the whole number expressed as sums.

The number of complementary addition facts of a number is one more than the number to be expressed. If zero facts are excluded, the number of complementary addition facts is one less than the number.

- C.** Fingers, square slips having 1, 2, 3.....10 squares, a pair of graduated rulers.

- D.** Using fingers of one hand write down the complementary addition facts of 5. Show the two numbers to be added: one number by folded fingers, and the other number by stretched fingers. Using fingers of both the hands, write down the complementary addition facts of 10. Show the two numbers to be added, one number by folded fingers and the other number by stretched fingers. *Fig. 3.3-1*

Take the slip having squares as many as the number whose complementary addition facts are to be determined. Fold the slip such that one part in whole squares is turned backwards. The number of squares in the portion at the back together with the number of squares in the portion at the front gives a complementary addition fact for the number of the slip. *Fig. 3.3-2*

Place two graduated rulers in such a way that 0 of the first ruler is against (just below or above) the number on the second ruler whose complementary addition facts are to be read off and the numbers on the second ruler run in the direction opposite to the numbers in the first ruler. *Fig. 3.3-3*

Read the pairs of numbers in alignment and the sum of each number pair is the number below or above zero and each sum is a complementary addition fact. *Fig. 3.3-4*

**3.4****A. Addition algorithm or process**

- B.** Ten ones are changed to one ten.

Ten tens are changed to one hundred

Ten hundreds are changed to one thousand and so on.

Eleven ones can be changed to 1 ten and 1 one and so on.

In adding multi-digit numbers, the digits in the same place are added, place by place, starting from ones place and changing units in

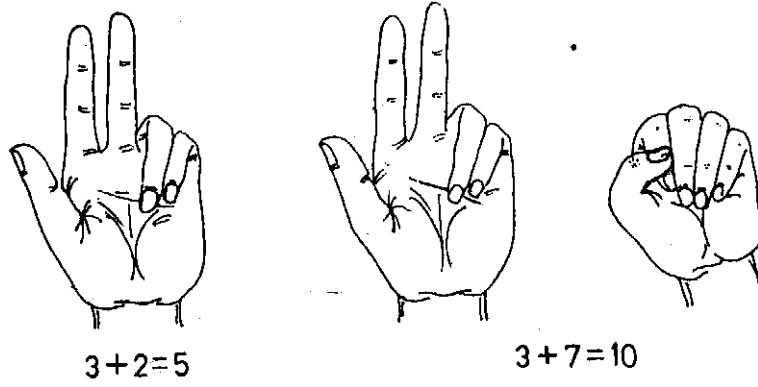

COMPLEMENTARY ADDITION FACTS WITH FINGERS

*Fig. 3.3-1*

SETTING OF GRADUATED RULERS FOR  
COMPLEMENTARY  
ADDITION

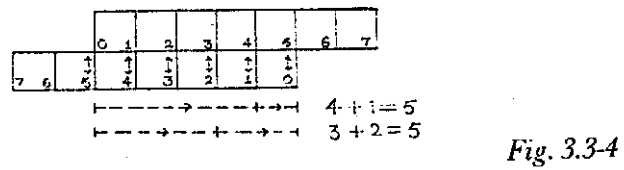
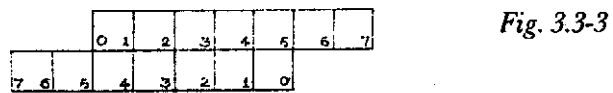

Complementary Addition Facts of 5



any place to the next higher unit (when it is possible) for being taken along with the digits in the next higher place.

C. Ten stick bundles, and loose sticks.

Ten slip bunches and loose slips for addition of two digit numbers.

Ten ten-slip or hundred stick bundles (9), ten stick bundles (10) loose slips (10).

Ten ten-slip or hundred slip bunches (9) ten slip bunches (10) and loose slips (10).

Ten by ten square sheets, 10 square slips and loose squares for addition of three digit numbers. Wooden base with holes at equal intervals, five rods (of equal height), beads or centrally holed bottle-tops for addition of four digit numbers or mid rib of banana or coconut leaf, broom sticks or bamboo spikes, castor stem rings or papaya stem rings.

Paper ten square column abacus.

D. *Addition of two two-digit numbers:*

Represent the two digit numbers by ten stick bundles and loose sticks or (ten slip bunches and loose slips or ten square slips and loose squares).

If the sum of loose sticks (or loose slips or loose squares) exceeds ten, change ten *ones* to obtain one *ten*, record units left and take the number of bundles (or bunches or slips) that is got along with the bundles (or bunches or slips) already there and find the total number of bundles (or bunches or slips) and record the tens. The sum is the outcome of addition:

*Addition of two three digit numbers:*

Represent the three-digit numbers by hundred stick bundles, ten stick bundles and loose sticks (or hundred slip bunches, ten slip bunches and loose slips, or 100 square sheets, 10 square slips and loose squares).

If the total number of loose sticks (or loose slips or loose squares) exceeds nine, change ten ones to obtain higher units of tens (bundles, bunches, strips), record ones left and take the number of bundles (bunches or strips) along with the higher units already there. If the total number of bundles exceeds nine, change ten tens (bundles, bunches or strips) to obtain higher units of hundreds (bigger bundles, bigger bunches, square sheets), record tens left and take the hundreds (bigger bundles, bigger bunches, square sheets) along with the hundreds already there and find the total number of hundreds and record the hundreds. The sum got is the outcome of addition.

*Addition of two four digit numbers:*

Do addition of two digit and three digit numbers on a five spike abacus, to gain experience in using abacus for addition. Observe that whenever there are more than nine beads on any spike, every ten of

them is replaced by one on the spike to the immediate left to get it along with higher units.

For addition of four digit numbers, represent the numbers on the abacus. Starting from the ones spike, observe the number of beads in ones spike. If the number exceeds nine, replace (every set of) ten beads in *ones spike* by one bead on *tens spike* (lying to the left).

Now observe the number of beads in tens place. If the number exceeds nine, replace (every set of) ten beads in tens place by putting one bead on hundreds spike. Carry on this process from spike to spike. Observe finally that the number of beads in every spike does not exceed nine. When the process stops the number represented on the abacus gives the sum of the (two) four digit numbers.

- E.** Use of abacus is not suggested from the beginning, because it is a semi concrete or semi-abstract apparatus, 'one bead representing ten beads'.

Concrete aids are resorted to to get familiar with and understand the ideas involved in a process. Once the mind gets seized of it and requires no further use of concrete aid, take off stage is said to be reached. So for addition and multiplication of numbers with digits exceeding four, no aids should be encouraged.

3.5

### A. Comparison of numbers

- B.** By one to one matching of collections representing two single digit numbers, the greater one can be easily determined. Of two natural numbers, the number with more digits is greater.

If, in two two-digit numbers, digits in tens place differ, then the number having tens place digit greater than the other is greater.

If, in two two digit numbers, digits in tens place are the same, the number having units place digit greater than the other, is greater.

If, in two three-digit numbers, digits in hundreds place differ, then the number having greater digit in hundreds place is greater.

If in two three-digit numbers, digits in hundreds place are the same, then the number having greater digit in tens place is greater.

If, in two three-digit numbers, digits in hundreds place are the same and digits in tens place are the same, then the number having greater digit in ones place is greater.

—and so on for other pairs of multi-digit numbers having the same number of digits.

- C.**  $10 \times 10$  square sheet, 10 square slips and loose squares. Two 4 -- spike abacus, beads or centrally holed objects.

- D.** For comparison of two numbers not having more than three digits, use  $10 \times 10$  square sheets, 10 square slips and loose squares for number representation and comparison starting with hundreds, then tens and then units.

For comparison of two numbers having more than three digits, use two abacuses for number representation and comparison starting from the highest place and going down step by step to ones. For **warming up**, start comparing pairs of two-digit numbers and pairs of three-digit numbers by representing the numbers on the abacuses.

- E.** For comparison of numbers having more than four digits, take off stage can be expected to be reached when no aids are used.

In teaching the symbols of inequality  $>$  and  $<$ , it is enough if one of these symbols alone is taught by appealing to situation as set out below:

*Fig. 3.5-1*

The other symbol becomes a natural orientation that can be made by the learner himself/herself. Hold the figure upside down.

**3.6**

### **A. Meaning of subtraction**

- B.** Subtraction arises out of *taking away situation* to find what remains, what is left of a collection (or quantity) when a part of it is removed. Subtraction arises out of *comparison situation* when two collections (or quantities) are compared and to find which of the two is greater and by how many (or how much) the smaller collection is less (or by how many the greater collection is more), subtract the number of the smaller collection from the number of the larger collection. Subtraction arises out of *complementary addition situation* to find out the number of objects (or quantities) to be added to the given collection of objects (or quantities) to get the number of objects in the required collection (or the required quantity).

- C.** Objects of different kinds, fingers, two graduated rulers.

- D.** Make a collection of objects and remove some objects from it. Find what remains by subtracting the number of objects removed from the number of objects in the collection. *Fig. 3.6-1*

Make a collection of objects. Close your eyes and ask somebody to remove some objects from the collection. Open your eyes and find out the number of objects removed by subtracting the number of objects remaining from the number of objects that was in the collection.

*Fig. 3.6-2*

Make a collection of objects of two kinds. If the number of objects of one kind (in smaller number) is given, find the number of objects of the *other* kind by subtracting the number of objects of the first kind from the number of objects in the whole collection. Make two collections of objects. To find which collection has less number of objects (or more number of objects), compare the numbers of the collections. To find by how many the smaller collection is smaller, subtract its

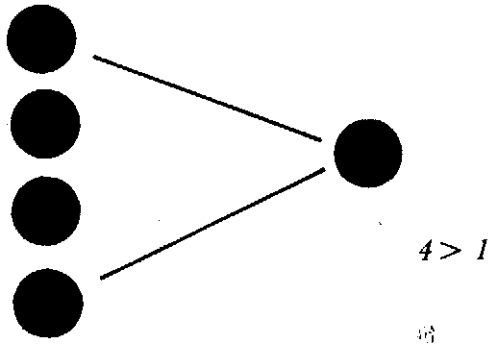
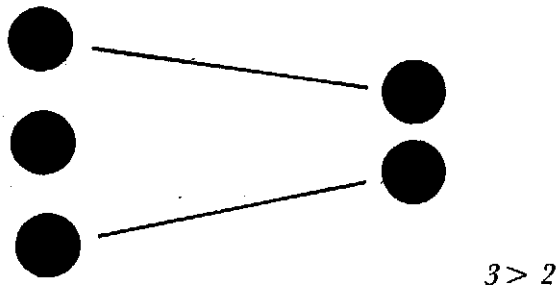

RATIONALE FOR THE SYMBOL > (Greater than)  
*Fig. 3.5-1*



FINDING WHAT REMAINS AFTER REMOVAL  
*Fig. 3.6-1*



FINDING WHAT IS REMOVED FROM THE REMAINING.  
*Fig. 3.6-2*

number from the number of the greater collection.

Make a collection of objects. Think of making a larger collection of the required number. To find how many more objects are to be taken along with the objects now available, subtract the number of the given collection from the number of the required collection and that gives the number of objects required further.

*Use of fingers:*

Stretch some fingers and count the stretched fingers. Fold some of these fingers and count the folded fingers. To find the number of the remaining stretched fingers, subtract the number of folded fingers from the number of the (*taking away*) fingers stretched in the beginning.

Stretch some fingers in the left palm. Stretch some fingers in the right palm. By comparing the numbers, find in which palm you have stretched more fingers. To find how many more fingers you have stretched in this palm, subtract the smaller number of fingers in one palm from the greater number of fingers in the other palm (*comparison*).

Think of stretching some fingers. Stretch some fingers (smaller than the number of figures to be stretched). To find how many more fingers you have to stretch, subtract the number of fingers stretched from the number of fingers thought to be stretched, (*complementary addition*).

*Use of a pair of graduated rulers:*

Fix one graduated ruler. Fix below it another graduated ruler in touch with the first ruler and with some number in the second ruler lying below a greater number in the first ruler. At zero of the second ruler, read the difference of the numbers on the first ruler (*taking away*).

*Fig. 3.6-3*

Fix two graduated rulers one lying below and along the other in such a way that their zeros are in alignment. The difference between a greater number on the first ruler and a smaller number on the second ruler is got by finding what more is to be added to the number on the second ruler to reach the number on the first ruler. (*complementary addition situation*).

*Fig. 3.6-4*

It can also be got by finding what is to be removed from the number or to find on the ruler the number to be reached on the second ruler (*comparison*).

*Fig. 3.6-5*

## 3.7

### A. Subtraction algorithm or process

B. 1 *ten* can be changed to 10 *ones*

1 *hundred* can be changed to 10 *tens*

1 *hundred* can be changed to 9 *tens* and 10 *ones* (see the illustration)

*Fig. 3.7-1*

# SUBTRACTION BY TAKING AWAY

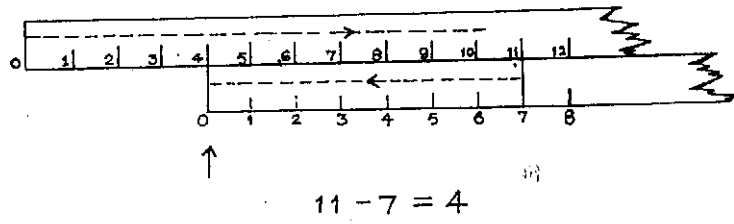
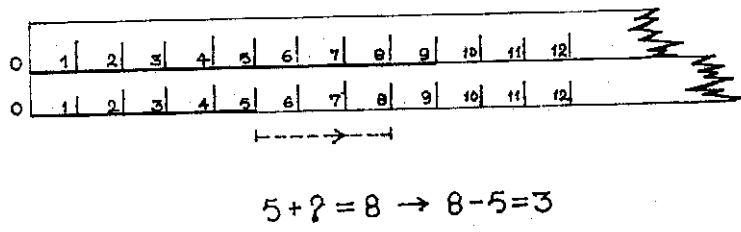

Fig. 3.6-3



# SUBTRACTION BY COMPLEMENTARY ADDITION

Fig. 3.6-4

# SUBTRACTION BY COMPARISON

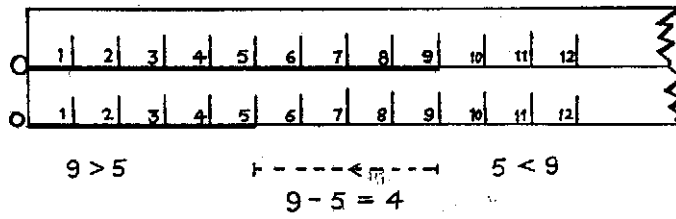

*Fig. 3.6-5*

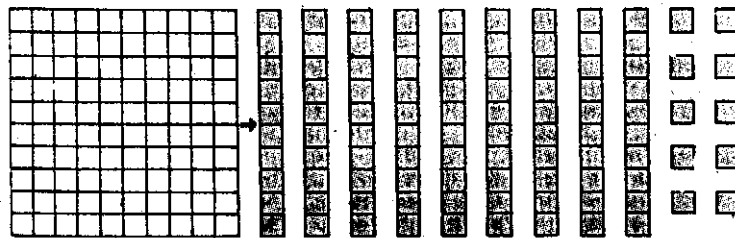

1 hundred = 9 tens and 10 Ones

*Fig. 3.7-1*

1 *thousand* can be changed to 10 *hundreds*  
1 *thousand* can be changed to 9 *hundreds*, and 10 *tens*,  
1 *thousand* can be changed to 9 *hundreds*, 9 *tens* and 10 *ones* and so on.

While subtracting a smaller multi-digit number (*subtrahend*) from a greater multi-digit number (*minuend*), if at any place the digit in the minuend is not enough to subtract the digit in the subtrahend, take one from the next higher unit (if it can be had) from the minuend and change it into ten of the units of the place for adding to the digit in the place of the minuend.

- C. Bundles of ten ten-stick bundles (or hundred stick bundle of bundles) ten stick bundles, loose sticks; bunches of ten ten-slip bunches or (of hundred slip bunch of bunches), ten slip bunches, loose slips; (or 10 ten-slip);

10 by 10 or hundred (or 10 ten-slip) square sheets.

10 square slips and loose squares.

Four spike abacus, beads, 10-square column paper abacus.

- D. *Subtraction of a smaller two-digit number from a greater two-digit number.*

Represent the greater two-digit number in terms of ten stick bundles and loose sticks. See if the required ten stick bundles and loose sticks representing the smaller two-digit number can be removed.

If there are not enough loose sticks (units) for removal of the required loose sticks (units), untie one ten stick bundle (change 1 ten) and take the ten sticks (10 ones) along with loose sticks. Remove the required number of loose sticks. Then remove the required number of ten stick bundles from the ten stick bundles on hand. What remains is seen in terms of ten stick bundles and loose sticks.

Use, instead of sticks, bunches of slips and square slips and proceed on similar lines.

*Subtraction of a smaller three digit number from a greater three digit number:*

Represent the greater three digit number in terms of hundred stick bundle of bundles, ten stick bundles and loose sticks. See if the required number of hundred stick bundle of bundles, ten stick bundles and loose sticks, representing the smaller three digit number can be removed. As before, whenever there are not enough sticks in a place for removal, increase the digit by 10 units of that place by changing 1 unit of the next higher place and proceed.

Use, instead of bundles of sticks, bunches of slips and square slips and proceed on similar times.

*Subtraction of a smaller four digit number from a greater four digit number:*

Represent on the abacus with beads the greater four digit number. To remove beads representing the smaller four digit number, start ins-



pecting from the units spike. If there are not enough beads in units spike place *remove one bead from tens spike* and put ten beads in the units spike place from where removal of the required number of ones is not possible. Now inspect if there are enough beads in tens spike for removing tens; if not, remove one bead from the hundreds spike and put ten beads in the tens spike and so on. Once there are enough beads in every spike for removing the required number of beads in each place of the smaller number, do the removal and record the difference. If at any stage, removing one bead from the next spike is not possible, remove one bead from the next higher.

- E. For subtracting a multidigit number with digits exceeding *four*, take off stage is expected to be reached by now when it is possible to adopt the process mentally without recourse to concrete aids.

### 3.8

#### A. Relations between addition and subtraction

- B. For every addition fact there are two subtraction facts.

For every subtraction fact, there is an addition fact.

For every subtraction fact, there is an associated subtraction fact.

- C. Objects, square slips.

- D. Take a collection of objects. Split the collection into two smaller collections. There are four ways of viewing the situation.

Subtracting the number of objects in one of the smaller collections from the number of objects in the original collection, the number of objects in the other smaller collection is obtained. *Fig. 3.8-1*

Observe that two subtraction facts can be got from one addition.

Knowing the number of one of the smaller collections, and the number of the original collection, the number of the other smaller collection can be obtained by subtraction. *Fig. 3.8-2*

Observe that from one subtraction, another associated subtraction can be obtained. *Fig. 3.8-3*

Knowing that the number of objects in one of the smaller collections is the number of the other smaller collection subtracted from the number of objects in the original collection, the number of objects in the original collection can be got by adding the numbers of objects in the two smaller collections.

Observe that an addition can be got from a subtraction.

- E. This experience is basic to solution of simple equations.

### 3.9

#### A. Skip counting and repeated addition

Instead of counting one ones (and tens), counting can be done in groups, say i. twos, threes, fours, fives and tens etc. The number of objects in all

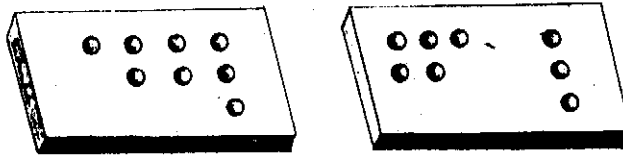

$5 + 3 = 8$   
 $\rightarrow 8 - 3 = 5$   
 and  
 $8 - 5 = 3$

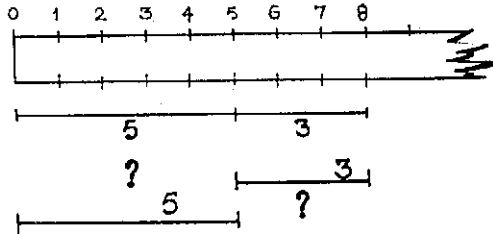
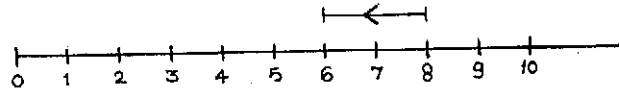
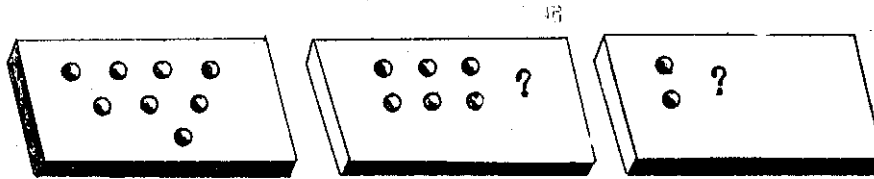
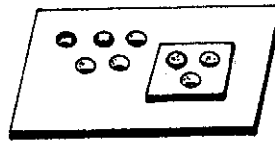

Fig. 3.8-1



$6 + 2 = 8 \Rightarrow 8 - 2 = 6 \Rightarrow 8 - 6 = 2$

Fig. 3.8-2



$3 = 8 - 5 \Rightarrow 5 = 8 - 3$

Fig. 3.8-3

the groups having equal number of objects can be got by skip counting. Repeated addition of number can be done by 'skip counting'.

- C. Seeds, finger marks, bunches of clipped paper slips.
- D. Seeds of a collection are arranged in pairs. Do skip counting 2, 4, 6 etc. find the number of seeds in the collection.  
Seeds in another collection are arranged in threes. Do skip counting 3, 6, 9 etc. and find the number of seeds in the collection.  
Using finger marks in the fingers of both the palms, do skip counting in twos and threes.  
Take bunches of clipped paper slips in fours and find the number of all the slips by skip counting.  
Count the objects of a collection in threes and if one or two objects are left towards the end, count in ones and find the total number.

### 3.10

#### A. Meaning of Multiplication

B. If two collections have equal number of objects and the collections are combined to form a large collection, the number of objects in the large collection when the two collections are combined, is twice (or 2 times) the number of objects in one of collections which is simply the sum of two equal numbers. The number of objects in the large collection when three such collections are combined is thrice or 3 times the number of objects in one of the collections and so on.  
The number of ways of pairing the objects of one collection with objects in another collection is the product of the numbers of the two collections.

C. Button cards, bunches of safety pins, seed packets, sticks, tongue scrapers, colour pencils.

D. Take 9 cards each having six buttons. Find the number of buttons in two cards by skip counting and record.

$$2 \times 6 = 12$$

$$3 \times 6 = 18 \text{ and so on,}$$

Make bunches of safety pins, each bunch having 5 safety pins. Find the number of safety pins in 2 bunches, 3 bunches etc. by skip counting and record

$$2 \times 5 = 10$$

$$3 \times 5 = 15 \text{ and so on.}$$

Make packets of seeds, each packet having 4 seeds. Find the number of seeds in 2 packets, 3 packets, etc. and record

$$2 \times 4 = 8$$

$$3 \times 4 = 12$$

$$4 \times 4 = 16 \text{ and so on.}$$

Beyond 5 times table, the process described below is handy.

Keep six sticks (or tongue scrapers) on the floor or table in such a way

that no two sticks (or tongue scrapers) meet or cut. Put one stick across and count the meeting points, read and record  $1 \times 6 = 6$ .

Put one more stick across, seeing that this does not meet the other stick across.

Count the meeting points, read and record  $2 \times 6 = 12$  and so on

*Fig. 3.10-1*

*The number of sticks one way  $\times$  the number of sticks the other way gives the number of meeting points.* Thus the basic multiplication table for any number can be obtained.

The most effective use of this criss-cross way is to get the multiplication facts of zero elegantly. Starting with a certain number of non-intersecting sticks lying in one way and a certain number of non-intersecting sticks across them, a certain multiplication fact is obtained. By reducing the number of 'across' sticks one by one till no stick is placed across, it is easy to see intuitively that a certain number (of sticks)  $\times$  zero (sticks across) gives zero (meeting points). Next reduce the number of sticks, the other way one by one, keeping the number of sticks across unchanged and realise that zero (sticks)  $\times$  a certain number (of sticks across) gives zero meeting points. Give colour pencils red and blue, say, to the child and keep colour pencils, green, violet and black, say, to yourself. Everytime you make a stroke with each of your colour pencils, let the child cut the stroke with each of her colour pencils. The number of pairs of strokes is  $2 \times 3 = 6$ .

### 3.11

#### A. Basic multiplication facts, properties and tables

**B.** When two single digit numbers are multiplied, the product is either a single digit number or a two digit number with 1 to 8 appearing in tens place. Multiplying a number by zero or multiplying zero by a number yields zero as product.

Multiplying a number by one or multiplying 1 by a number yields the number itself as product. Multiplying zero by zero yields 0 as product.

**C.** Seeds, square ruled sheet, broom sticks (18), tongue scrapers (18).

**D.** Make packets of equal number of seeds, the number varying from 1 to 5. Take one packet, read and record  $1 \times 5 = 5$ . Take two packets and find the number of seeds in them, read and record  $2 \times 5 = 10$  and so on. *Fig. 3.11-1*

*Use of 18 broom sticks (tongue scrapers) in building basic multiplication facts tables.* Finally take a certain number of sticks one way and a certain number of sticks across them.

MULTIPLICATION FACTS BY CRISS CROSS  
ARRANGEMENT OF STICKS

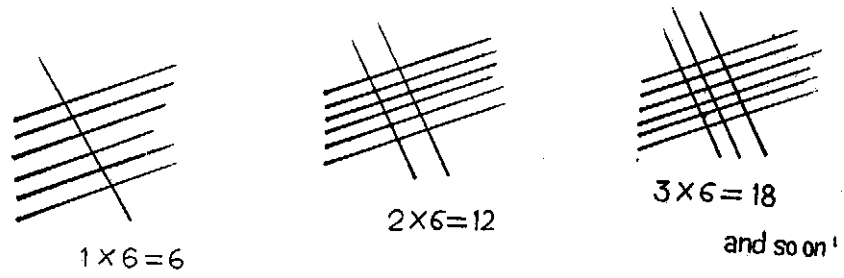

Fig. 3.10-1

BUILDING MULTIPLICATION TABLE FIVE

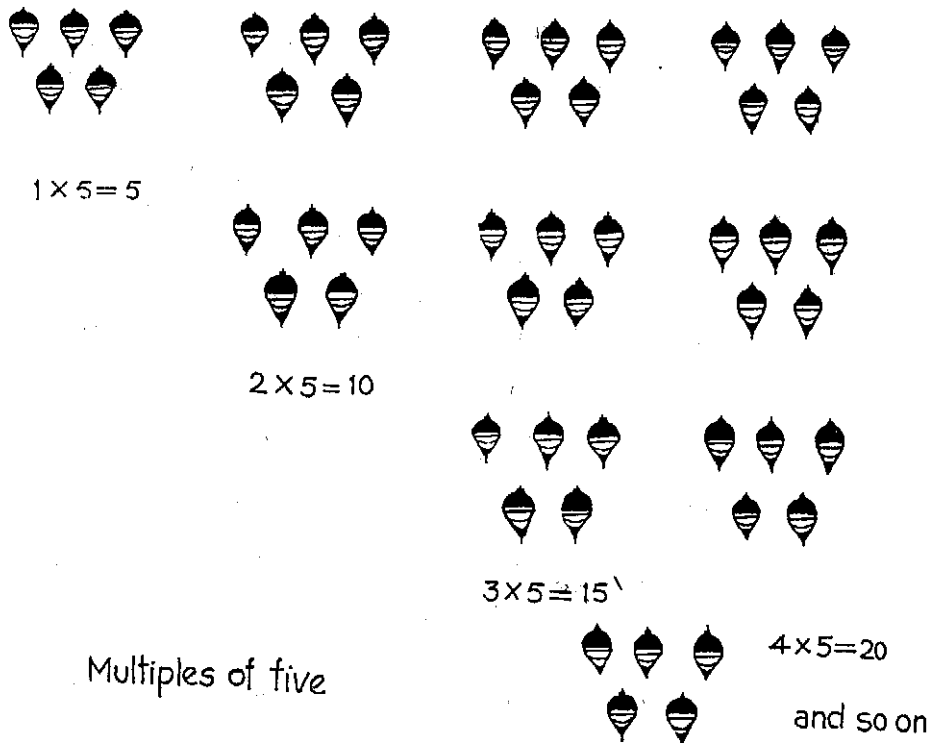

Fig. 3.11-1

Reduce the number of sticks either way and realise that zero (sticks one way)  $\times$  zero (sticks the other way) gives zero meeting points.

*Use of square ruled sheet: Fig. 3.11-2*

Cut out, say, 9 rows of 7 squares each. By skip counting in sevens or by counting one by one, build 7 times table

$$1 \times 7 = 7$$

$$2 \times 7 = 14 \text{ and so on. } \textit{Fig. 3.11-3}$$

Children sit in 9 rows of eight each. They stand up row by row, with no row sitting once having stood up. This gives 8 times table.

*Rectangular array*

Take a buttons card, showing 24 buttons in a rectangular array. Look at it in one way, you find 4 rows of 6 buttons each, giving  $4 \times 6 = 24$ .

Turn it to show 6 rows of 4 buttons each, giving  $6 \times 4 = 24$ .

Observe a block with 24 cubes. Looking at it in one way, you find 4 layers of 3 rows, each row having 2 cubes.

$$4 \times 3 \times 2 = 24.$$

Turn it round without disturbing the set up. Now you observe 3 layers of 2 rows, each row having 4 cubes each.  $3 \times 2 \times 4 = 24$ . Again turn it round without disturbing the set. Now you observe 2 layers of 4 rows, each row having 3 cubes each.

$$2 \times 4 \times 3 = 24.$$

Observe that in multiplying numbers, the order does not count. *Fig. 3.11-4*

You have already seen through use of criss-cross setting of broom sticks that  $0 \times \text{any number} = 0$  and  $\text{any number} \times 0 = 0$  and in particular  $0 \times 0 = 0$ . You have also seen through the use of criss-cross setting of broom sticks that  $1 \times \text{any number} = \text{the number}$  and  $\text{any number} \times 1 = \text{the number}$  and in particular  $1 \times 1 = 1$ .

*Multiplication and addition*

With punching pliers and folded paper, make an array of four rows of eight holes each.

Cut off the paper into two parts such that on one part there appears 4 rows of 5 holes each and on the other part 4 rows of 3 holes each. Observe that  $4 \times 8 = 4 \times 5 + 4 \times 3$ .

In other words  $4 \times (5+3) = 4 \times 5 + 4 \times 3$  and vice versa. This shows that 'the product of a sum is the sum of the products', giving the *distributive property of multiplication over addition*. *Fig. 3.11-5*

Record the 100 basic multiplication facts of single digit numbers 0 to 9 in a square table. Observe that there are 19 multiplication facts of 0, 19 multiplication facts of 1 and by rearrangement property 45 facts can be got from the other multiplication facts. *Fig. 3.11-6*

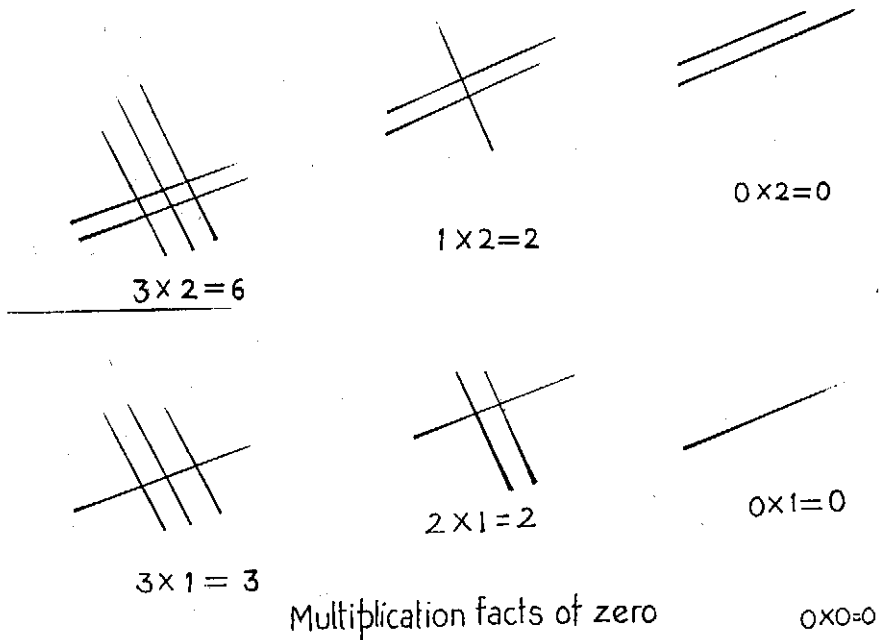

Fig. 3.11-2

MULTIPLICATION TABLE SEVEN

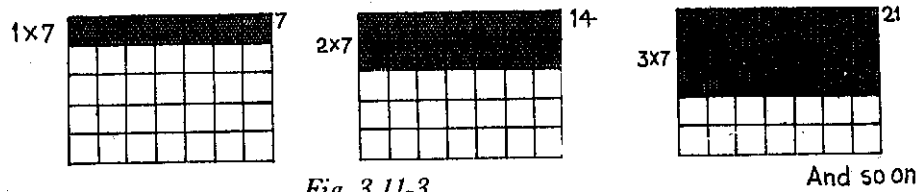

Fig. 3.11-3

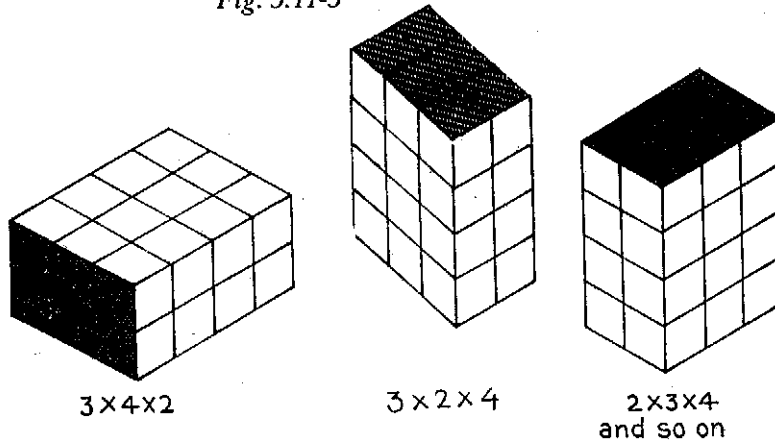
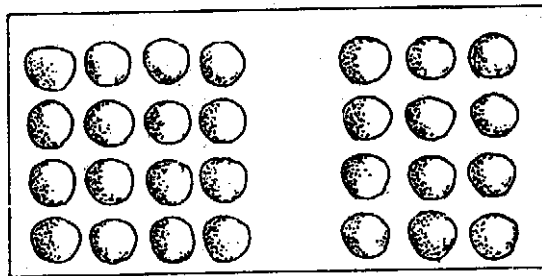

Fig. 3.11-4



$$4 \times 8 = 4 \times 5 + 4 \times 3$$

Fig. 3.11-5

### BASIC MULTIPLICATION FACTS TABLE

x	0	1	2	3	4	5	6	7	8	9
0	0	0	0	0	0	0	0	0	0	0
1	0	1	2	3	4	5	6	7	8	9
2	0	2	4	6	8	10	12	14	16	18
3	0	3	6	9	12	15	18	21	24	27
4	0	4	8	12	16	20	24	28	32	36
5	0	5	10	15	20	25	30	35	40	45
6	0	6	12	18	24	30	36	42	48	54
7	0	7	14	21	28	35	42	49	56	63
8	0	8	16	24	32	40	48	56	64	72
9	0	9	18	27	36	45	54	63	72	81

Fig. 3.11-6



**A. Multiplication algorithm or process**

- B.** Having ten in units column is the same as having 1 in the tens column  
 $1 \times 10 = 10$ .

Having a certain number in any place value column gives a multiplication fact eg.  $3 \times 100 = 300$ . Multiplication of a number by a higher unit (10, 100, 1000 etc.) is obtained by annexing to the number as many zeros as there are in the higher unit. Multiplication algorithm is based on distributive property of multiplication over addition.

- C.** Six spike abacus and beads.

Ten square column paper abacus.

- D.** Take a certain number of beads (less than nine) in units spike. Transfer them to the tens spike. Now the same number of beads represents tens. Record this as a multiplication of the number by tens.

*Fig. 3.12-1*

Take a certain number of beads (less than nine) in units spike. Transfer them to the hundreds spike. Now the same number of beads represents hundred. Record this as a multiplication of number by hundreds.

*Fig. 3.12-2*

Observe that moving beads from any spike to next spike to the left makes the value of the beads 10 times. *Fig. 3.12-3*

$$30 \times 10 = 300 \quad 300 \times 10 = 3000.$$

Observe that moving beads from any spike to the second spike to its left makes the value of beads 100 times. *Fig. 3.12-4 Fig. 3.12-5*  
 And so on.

*Multiplication of a two digit by a single digit number:*

Represent the two digit number on the spike as many times as the single digit number. Set right the abacus if necessary by suitable transfers starting from units spike so that no spike has more than 9 beads, using the place value principle that ten beads in any spike should be replaced by one bead in the higher place value spike to its immediate left. The final representation gives the required product.

*Multiplication of a two digit number by a two digit number: Fig. 3.12-6*

Represent the multiplicand two digit number on the spike. Split the multiplicand two digit number as so many tens and so many units. To multiply by ten, transfer the beads in each column to the corresponding spike to its left, starting from the left most spike containing beads. Put as many beads now in the spikes as there are tens.

Repeat representation of the multiplicand two digit number as there are units in the multiplier two digit number.

Set right the abacus if necessary by suitable transfers so that, starting from the units spike no spike has more than 9 beads, using the place value principle. *Fig. 3.12-7*

MULTIPLICATION BY HIGHER UNITS  
AND  
SHIFTING OF PLACE VALUES

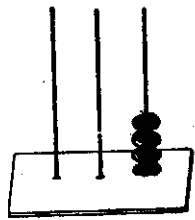

4  
 $4 \times 1 = 4$

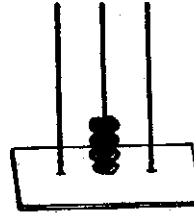

40  
 $4 \times 10 = 40$

*Fig. 3.12-1*

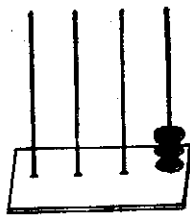

3  
 $3 \times 1 = 3$

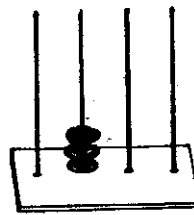

300  
 $3 \times 100 = 300$

*Fig. 3.12-2*

MULTIPLICATION BY 10 AND SHIFTING OF  
BEADS TO THE NEXT SPIKE ON THE LEFT

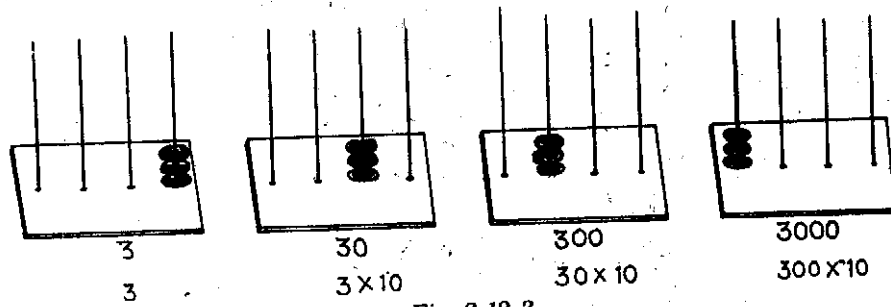

*Fig. 3.12-3*

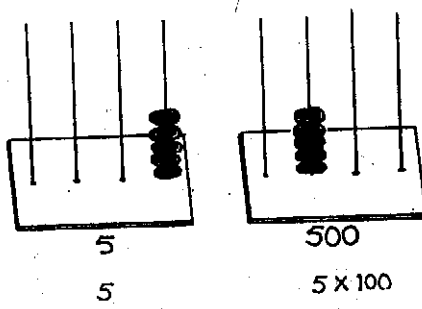

*Fig. 3.12-4*

# MEANING OF MULTIPLICATION PROCESS

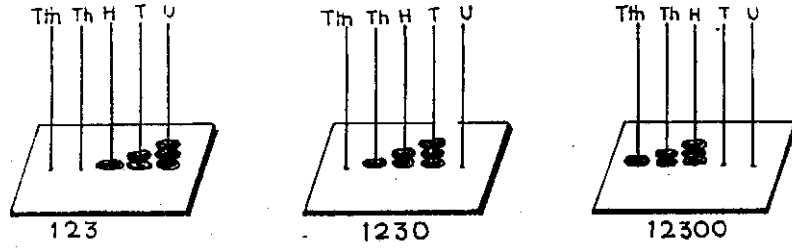

Fig. 3.12-5

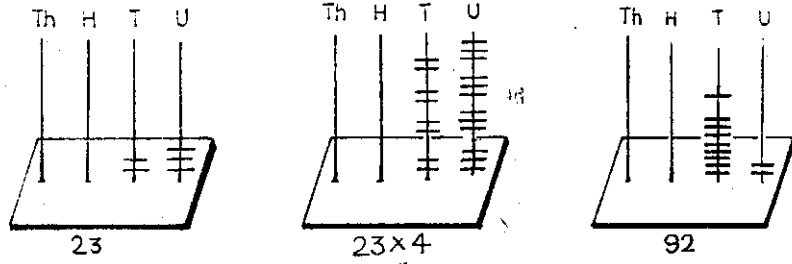

Fig. 3.12-6

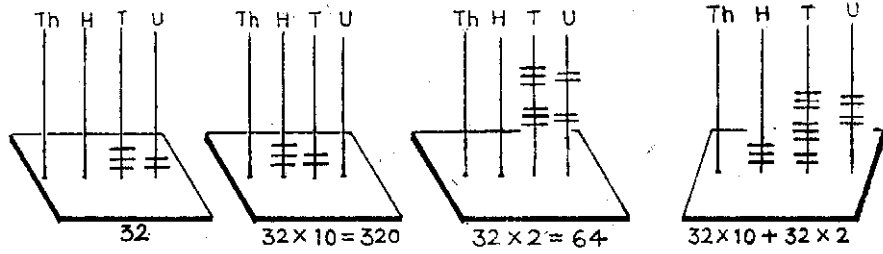

Fig. 3.12-7

$$\begin{array}{r} 32 \times 12 \\ \underline{320} \\ 64 \\ \hline \end{array}$$

- E.** For multiplying a multidigit number (number of digits exceeding two) by another multidigit number. (number of digits exceeding two), no more concrete aid should be necessary, as the take off stage could be assumed to have been reached after the above experiences.

### 3.13

#### A. Meaning of division

- B.** Division arises out of *distributing* a certain number of things *equally* among a certain number of places, (*rate*). Division arises out of making *groups of equal number* of things from a certain number of things (*ratio*). Division arises out of finding the number of groups of equal number of things required to get a certain number of things. (*complementary multiplication*) Division arises out of finding the number of things in one of collections, when the number of pairings of things in one collection with things in the other collection are known.
- C.** Common objects (buttons, seeds, pebbles, bottle tops), square slips of the same size.
- D.** Take a certain number of objects, say 12. Distribute them equally among a certain number of places, say 3. Observe that each place gets 4 objects. The rate of distribution is 4 per place. (In the place of objects, consider fruit, money, etc. and in the place of places, consider packets, persons etc and interpret the rate) Read and record the division

$$12 \div 3 = 4 \text{ or } \frac{12}{3} = 4$$

Fig. 3.13-1

Take a certain numbers of objects, say 20. Group them to have five objects in each group. Observe that there are 4 groups. *The ratio of grouping is 5: 1.* (in the place of objects, consider books, tablets, etc and interpret the ratio)  
Read and record the division

$$20 \div 5 = 4 \text{ or } \frac{20}{5} = 4.$$

Fig. 3.13-2

At the rate of a certain number of objects per group say 6, find the number of groups required to get 12 objects. The number of groups required is 2 and record the division fact

$$12 \div 6 = 2 \text{ or } \frac{12}{6} = 2.$$

DIVISION BY EQUAL DISTRIBUTION (Rate)

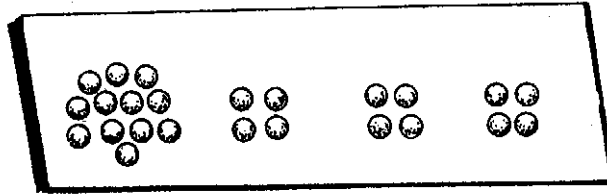

$$12 \div 3 = 4 \text{ Or } 12/3 = 4$$

Fig. 3.13-1

Division by grouping (ratio)



$$20 \div 5 = 4 \text{ or } 20/5 = 4$$

Fig. 3.13-2



Division by complementary multiplication

$$6 \times ? = 12 \rightarrow 12 \div 6 = 2$$

Fig. 3.13-3

(in the place of things, consider tablets, oranges and in the place of groups, consider packets, baskets etc. and interpret the complementary multiplication) *Fig. 3.13-3*

There are a certain number of things, say 4 in a collection and these are to be paired in the required number of ways, say 20, with objects in another collection. Observe that to find the number of objects in the second collection, division is involved

$$20 \div 4 = 5 \text{ or } \frac{20}{4} = 5.$$

In the place of things in the first collection, consider blouses, ties etc. and in the place of pairing, consider matching and in the place of objects in the second collection, consider skirts, shirts etc. and interpret the division.) *Fig. 3.13-4*

### **Division algorithm or process**

**3.14**

**B.** *Repeated subtraction is division.* Division of a certain two-digit number by a single digit number to find how many times the single digit number can be subtracted from the two-digit number can be done by the use of basic multiplication facts.

*Distributing way.* Division also means the highest number of times the divisor number can be taken from the dividend number. A multidigit number is represented in units, tens, hundreds etc. Division means distribution of these 'denominations' equally in the required places. When the division is not perfect or exact, there is a remainder.

Dividing say, 71 by 3, means distributing 7 ten-square strips and a square slip equally in 3 places; firstly 2 ten-square strips can be placed in each place. There is left 1 ten-square strip; change it into 10 square slips. Already there is 1 square slip. Together the number of square slips is 11. Distributing 11 square slips equally in 3 places, 3 square slips can be placed in each place, leaving 2 squares. Observe that each place contains 2 ten-square strips and 3 squares. So the quotient is 23 and the remainder is 2.

*Division of a three digit number by a single digit number i.e.  $315 \div 4$*   
Take 3 ten  $\times$  ten or hundred-square sheets, 1 ten-square strip and 5 squares. Fix 4 places. Find how the square sheets, strips and squares can be distributed equally in 4 places.

Hundred-square sheets are not enough for equal distribution in 4 places. So change 3 hundred-square sheets into 30 ten-square strips. Already there is 1 ten-square strip. Together there are 31 ten-square strips. Now in each place, put 7 ten-square strips. 3 ten-square strips are left. Change 3 ten-square strips into 30 squares. Already there are 4 squares. Together there are 34 squares. Distributing equally 34 squares in 4 places, each place gets 8 squares; giving a remainder of 3 squares. So the quotient is 78 and remainder 2.

MULTIPLICATION AND DIVISION BY CARTESIAN PRODUCT

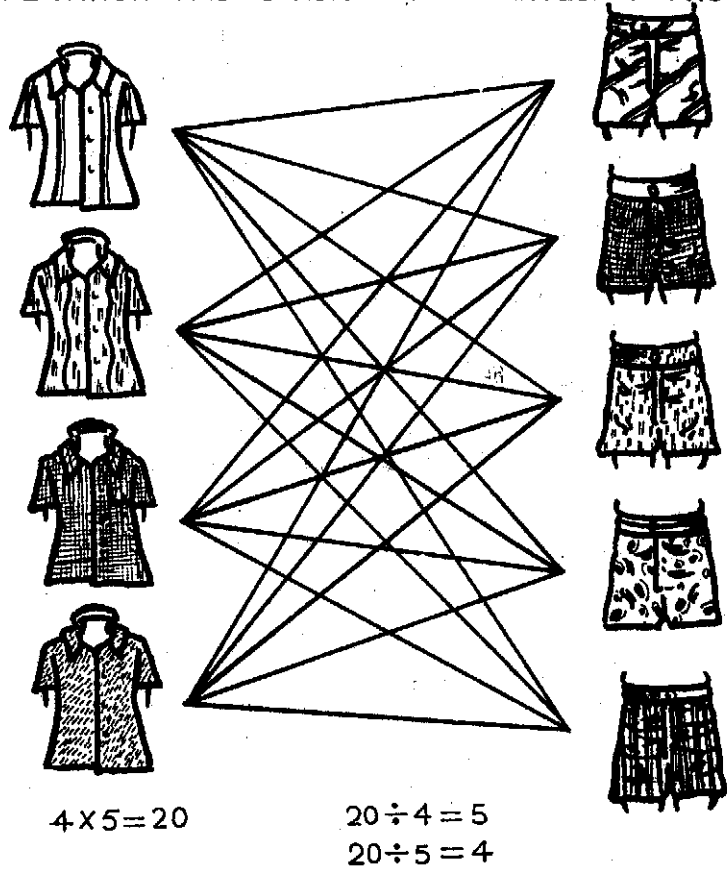

*Fig. 3.13-4*



- C. Seed packets,  $10 \times 10$  square sheets, ten-square slips, punching pliers and paper.

*Grouping way*

Take a two digit number, say 71 and consider division of it by 3. Division can be done by repeated subtraction. To speed up subtraction, prepare a paper punched with 71 holes in three. Prepare paper strips punched to show ten rows of 3 holes each. Find how many times these strips will align with 71 holes in 3 hole rows to the maximum. Observe that 2 strips are required, meaning 20 threes are subtracted. There are left 11 holes. Observe that 3 can be taken out three times leaving 2 holes. So the number of times 3 can go into 71 is  $20 + 3 = 23$  times, leaving the remainder 2. *Fig. 3.14-1*

*Distribution way*

Take 7 ten-square strips and 1 square slip. Fix 3 places. Consider distribution of strips and squares equally in 3 places. *Fig. 3.14-2*

- E. Once the division process is understood, division of a multidigit number (with number of digits exceeding 2) by a multidigit number (number of digits exceeding 1) can be done without resorting to concrete aids but in usual stages as illustrated in text books.

**A. The relations between multiplication and division 3.15**

- B. For every multiplication fact, there are two division facts. For every division act there is an associated multiplication fact.

For every division fact, there is an associated division fact.

A number ( $\neq 0$ ) divided by itself is one.

*One* divides every number without remainder.

*Zero* is divisible by any number.

Dividend = divisor  $\times$  quotient + remainder.

Remainder is less than (or equal to the dividend when the dividend is less than the divisor) the divisor in division, when the division is completed.

- C. Objects, square ruled sheets.

- D. Arrange objects in a rectangular array. Observe that if the number of objects and the number of rows of the array are known, the number of objects per row can be obtained by dividing the number of objects by the number of rows. *Fig. 3.15-1*

Also if the number of objects and the number of objects per row are known, the number of rows can be obtained by dividing the number of objects by the number of objects per row.

Observe that a multiplication fact yields two division facts.

The number of objects per row is known and the number of rows is known. When one is the divisor, the other is the quotient. Observe that the product of the two numbers gives the dividend. So a division fact yields an associated multiplication fact. *Fig. 3.15-2*

# DIVISION BY GROUPING AND TAKING AWAY

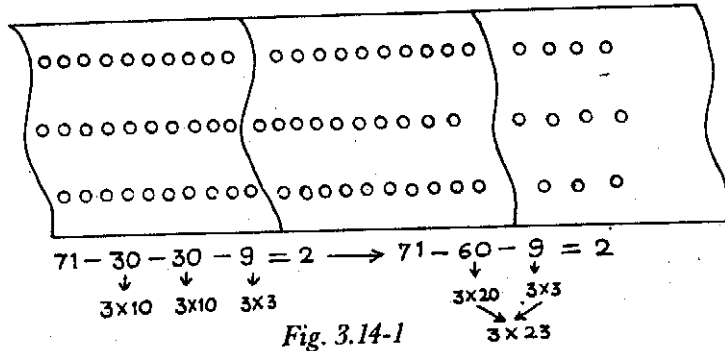
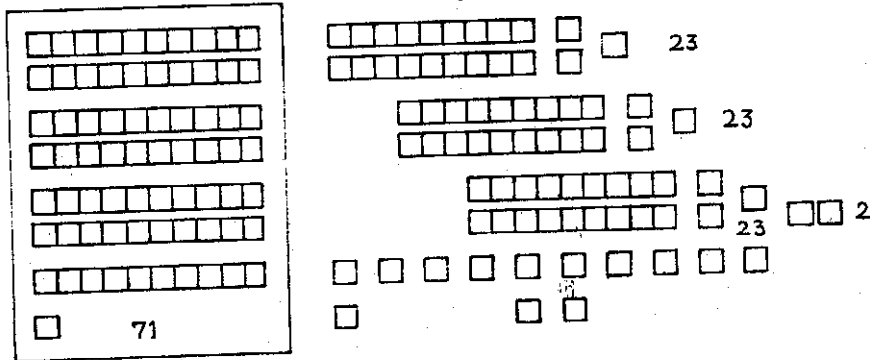

Fig. 3.14-1

Division by distribution



- 71 → 7 tens and one 1
- 2 tens in 3 places and changing 1 ten into 10 ones and taking along one 1
- 2 tens in 3 places and 3 ones in 3 places with 2 ones left.

Fig. 3.14-2

# RELATIONS BETWEEN DIVISION AND MULTIPLICATION

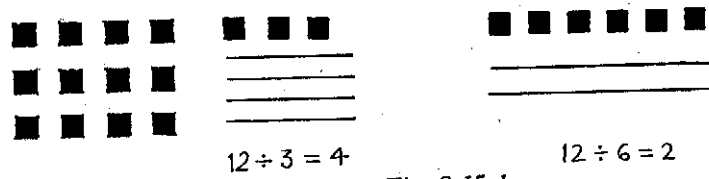

Fig. 3.15-1

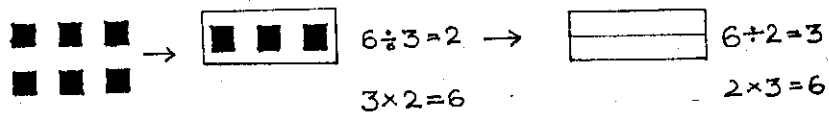

Fig. 3.15-2

The number of objects divided by the number of rows gives the number of objects per row. Observe that in such cases the number of objects divided by the number of objects per row gives the number of rows. So for every division fact there is an associated division fact.

Any number of objects can be arranged in a single row, showing that a number ( $\neq 0$ ) divided by itself is 1 and a number divided by 1 is the number itself. If there are zero things, zero things can be placed in as many places as one likes. So zero divisible by any number ( $\neq 0$ ) is zero.

When taking away a certain number of objects at a time, that is when division, stops, the remainder is less than the divisor. If the remainder is more than or equal to the divisor, division process or taking away will continue. *Fig. 3.15-3*

- E. No number is divisible by zero. Explaining that is beyond the scope of primary maths.

Division is repeated subtraction

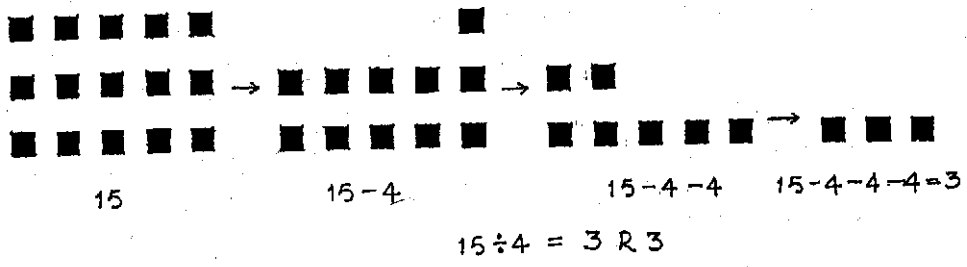

Fig. 3.15-3

## UNIT IV

### **Kinds of Numbers and their Properties etc (Subsets of the Natural Number Systems etc)**

- 4.1 Cardinal and ordinal numbers
- 4.2 Odd and even numbers
- 4.3 Factor and multiple
- 4.4 Prime and composite
- 4.5 C.M. and L.C.M.
- 4.6 C.F. and H.C.F.
- 4.7 Relatively prime or coprime

#### **A. Cardinal and ordinal numbers:**

**4.1**

- B.** A *cardinal* number answers '*how many*' in a collection and ordinal number '*which one*' in a collection.
- C.** Children, a set of cards numbered 1 to 12, any book having numbered pages.
- D.** Children stand in a row facing you and are assigned numbers 1, 2, 3 etc from the left end (or right end). Call any child by his number. Only one child is seen to answer; e.g. 3rd child or child 3; giving ordinal use of number. *Fig. 4.1-1*

Call three children. Any three children can be seen to answer, giving cardinal use of numbers.

Call the first three children to come forward, giving both the ordinal and cardinal use of numbers.

Jumble the numbered cards. They can be arranged again in order. While jumbling, the number of cards remains the same (cardinal). While arranging them, we look for positions in the order of numbers (ordinal).

Showing any numbered page (say 30th) and then showing that number of pages (say 30) give experience in distinguishing ordinal use of a natural number from its cardinal use.

#### **A. Odd and even numbers**

**4.2**

- B.** Evenness or oddness of a number does not depend on counting.  
If a collection of objects is such that the objects can be grouped in pairs without any one object left out, the number of the collection is even; otherwise it is odd.  
*A number is either even or odd.*
- C.** Common objects, square slips of paper of the same size, children.

CARDINAL AND ORDINAL USE OF NUMBERS

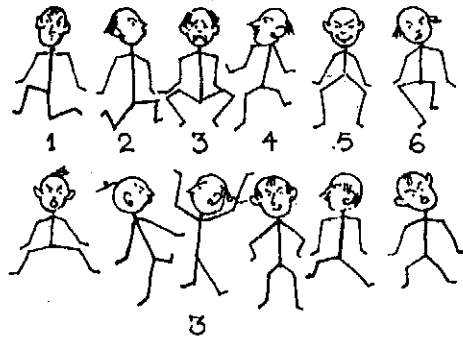

Fig. 4.1-1

EVEN OR ODD

Collection



Pairing Complete



The number of the collection is even



Collection



Pairing Incomplete

The number of the collection is odd

Fig. 4.2-1

- D.** A collection of objects is taken and the objects are grouped in pairs. This grouping finds one object left out. The number of the collection is odd. This is imperfect pairing. If the objects in a collection can be paired perfectly, the number of the collection is even. Count the number of objects and say that the number is odd or even according as pairing is imperfect or perfect. *Fig. 4.2-1*

Take a collection of square slips. Try to form a rectangular array having only two rows. If it is possible, then the number of the collection is even; otherwise it is odd.

Children stand in a row. Order them to stand in twos. If no child is left out, the number of the children is even. If one child is left out, the number of the children is odd.

**4.3**

### **A. Factor and multiple**

- B.** A rectangular array has rows of objects and equal number of objects in each row. If two numbers are multiplied, the product number is the multiple of either of the two numbers and each of the two numbers is a factor of the product number.
- C.** Common objects, square ruled sheet.
- D.** Objects can be so chosen as to have them arranged in a rectangular array. i.g. 4 columns of 3 objects each. *Fig. 4.3-1*

Count the number of objects in the array and that number is a multiple of the number of rows as well as the number of objects in each row. The number of rows and the number of objects in each row are factors of the number of objects in the array.

Children can form rectangular arrays in different ways. They can identify multiples and factors, each time.

Cut out rectangles (including squares) from a square ruled sheet along the rulings, read the multiples and the factors in each case.

*Fig. 4.3-2*

**4.4**

### **A. Prime and composite numbers**

- B.** A natural number is prime, when it has only two distinct factors, 1 and the number itself. 1 is neither prime nor composite.
- C.** Common objects, square slips of paper of the same size, children.
- D.** When a collection of objects cannot be arranged to form a rectangular array (with more than one row), the number of the collection is prime. Otherwise it is composite. *Fig. 4.4-1*

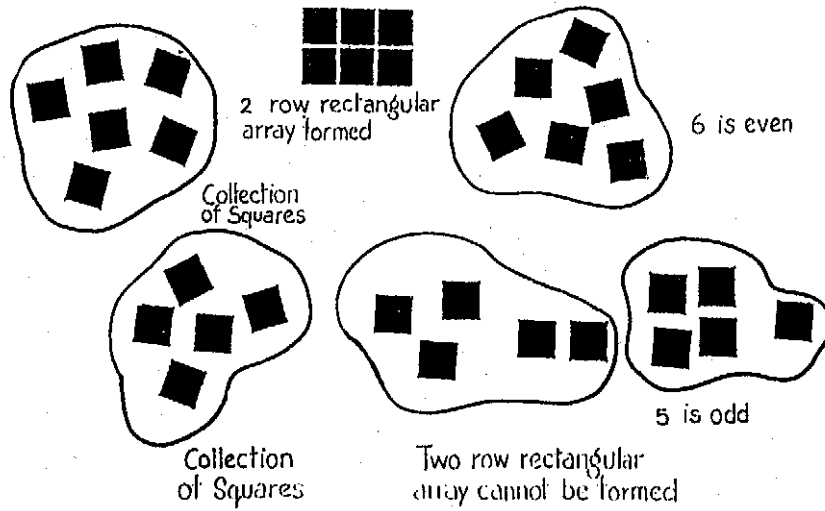
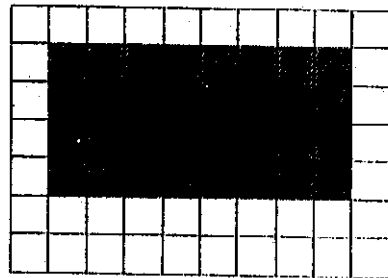
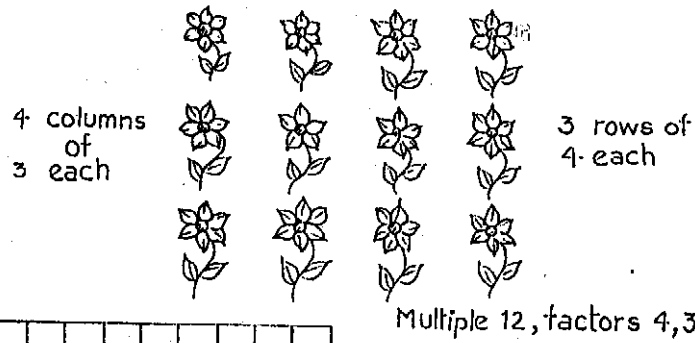

Fig. 4.2-2

A Whole Number is Either Odd Or Even

Array of 12 objects



Multiple 32  
Factors 4, 8

Fig. 4.3-1

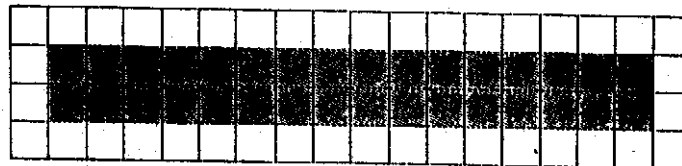

Multiple 32  
Factors 2, 16

4.3-2





A group of children can try to form rectangular (including square) arrays. If they succeed, their number is composite. Otherwise it is prime.

Take a collection of square slips of paper and examine if they can be arranged to form a rectangle (with more than one row). If it is possible, the number of square slips is composite; otherwise it is prime.

Take a collection of 15 square slips. They can form a rectangular array having 3 rows (of 5 each) or 5 rows (of 3 each).

- E.** To decide if 2 is prime or composite, and to find if 1 is prime or composite, drawing up a factor table is necessary. 2 has only two factors 1 and 2. So 2 is prime. 1 has only one factor which is nothing but itself, so 1 is neither prime nor composite. Sometimes a prime number is defined to be a number that is divisible by itself and 1. Under this criterion 1 is sometimes taken as prime by some mathematicians. Children confuse odd and even numbers with prime and composite numbers. Nine is odd but not prime. Two is even but not composite. *Every prime greater than two is odd.*

4.5

### A. CM and LCM

- B.** C.Ms, (common multiples) and L.C.M. (the least common multiple) of numbers is a property of numbers and they do not depend on their numerals (or basis of counting).

A natural number has multiples. Two (or more) natural numbers have common multiples.

Among the common multiples of two (or more) natural numbers the least of the common multiples is the L.C.M. (the least common multiple) of the two (or more) natural numbers.

If a number and its multiple are taken, the multiple itself is the L.C.M. of both. If equal numbers are taken, either of them is the L.C.M. of both.

- C.** Common objects, square ruled sheet.

- D.** Take any two numbers (less than ten) and represent them by collections of objects arranged in a row. Take multiples of them in order, such as once, twice, thrice, four times etc. of the collections and arrange them in separate columns. Examine when columns and rows of objects match one to one. The numbers of objects in such rows give common multiples (CM) of numbers and the number of the shortest row of objects in the rows of either collection is the least common multiple (LCM) of the numbers. *Fig. 4.5-1 Fig. 4.5-2*

From the square ruled sheet, cut out strips of squares representing the chosen two numbers. Arrange strips representing multiples of each number in separate columns. Pick out strips of squares which

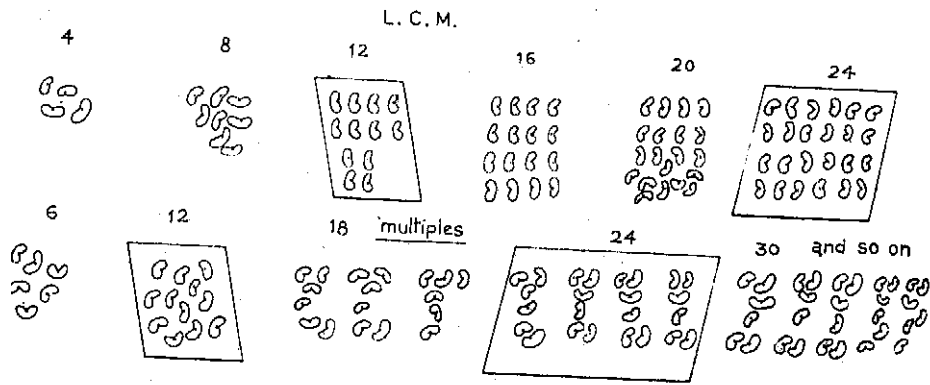

Fig. 4.5-1

MULTIPLES, COMMON MULTIPLES, THE LEAST COMMON MULTIPLE

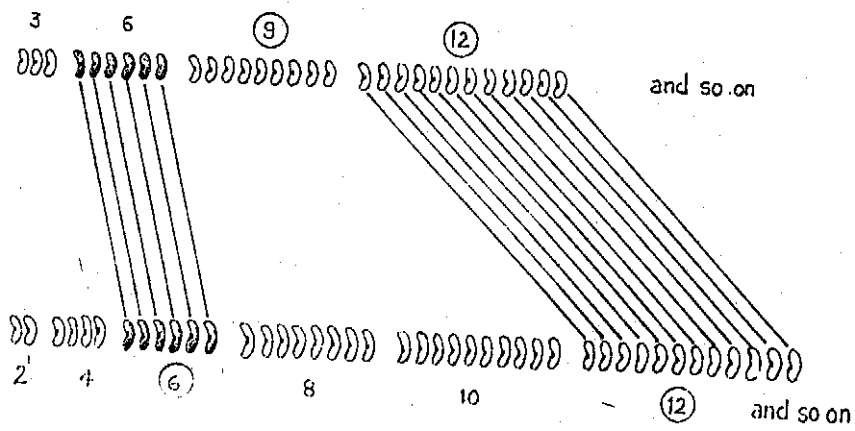

Fig. 4.5-2

are identical in each case. The numbers of such strips give the common multiples (CM) of the two numbers and the number of the shortest strip in either case gives the LCM of the two numbers.

Take two numbers such that one is a multiple of the other. By means of objects or square ruled sheet, observe that the multiples of the greater number are all common multiples of both the numbers, showing that the greater number is their LCM. *Fig. 4.5-3*

4.6

#### A. CF and HCF

**B.** CFs (common factors) and HCF (the highest common factor) of natural numbers is a property of numbers and they do not depend on their numerals (or counting). A natural number has factors. Two (or more) natural numbers have common factors (CF). Among the common factors of two (or more) natural numbers, the highest of the common factors is the HCF (the highest common factor) of the two (or more) natural numbers. If a number and its multiple are taken, the number is then the HCF of the two numbers. If two numbers are equal, either of them is their HCF.

**C.** Common objects, square ruled sheet.

**D.** Take two numbers and represent them by collections of objects each. Each collection can be displayed to show ones. Examine if each collection can be displayed to show groups of twos. If either of the collection does not lend itself to display of groups of twos, discard grouping the collections by twos.

Continue exploration for grouping by threes, fours and so on. Whenever the two collections can each be grouped in equal number of objects, the number in such grouping is a common factor (CF) of the two numbers and the greatest number that characterises such common grouping is the (HCF) highest common factor of the two numbers. *Fig. 4.6-1*

From the square ruled sheet cut out rows of squares representing the numbers chosen. Examine if each of the rows of squares can be cut into smaller rows of squares, with the same common number of squares. Numbers of squares in such smaller rows are the CF (common factors) of the two numbers. The number of squares in the largest of the rows is the HCF of the two numbers.

Take two numbers such that one is a multiple of the other. By means of objects or square ruled sheet, observe that the factors of the smaller number are all common factors of both the numbers, showing that the smallest number is their HCF. *Fig. 4.6-2*

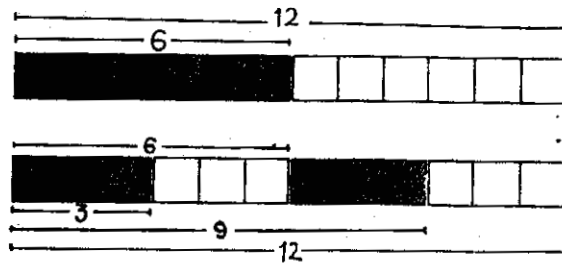

Multiples,  
common multiples,  
The Least common multiple

Fig. 4.5-3

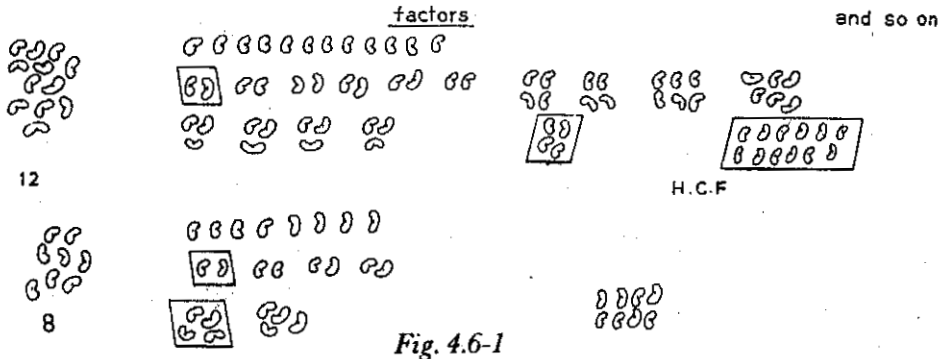

Fig. 4.6-1

FACTORS, COMMON FACTORS, THE HIGHEST COMMON FACTOR

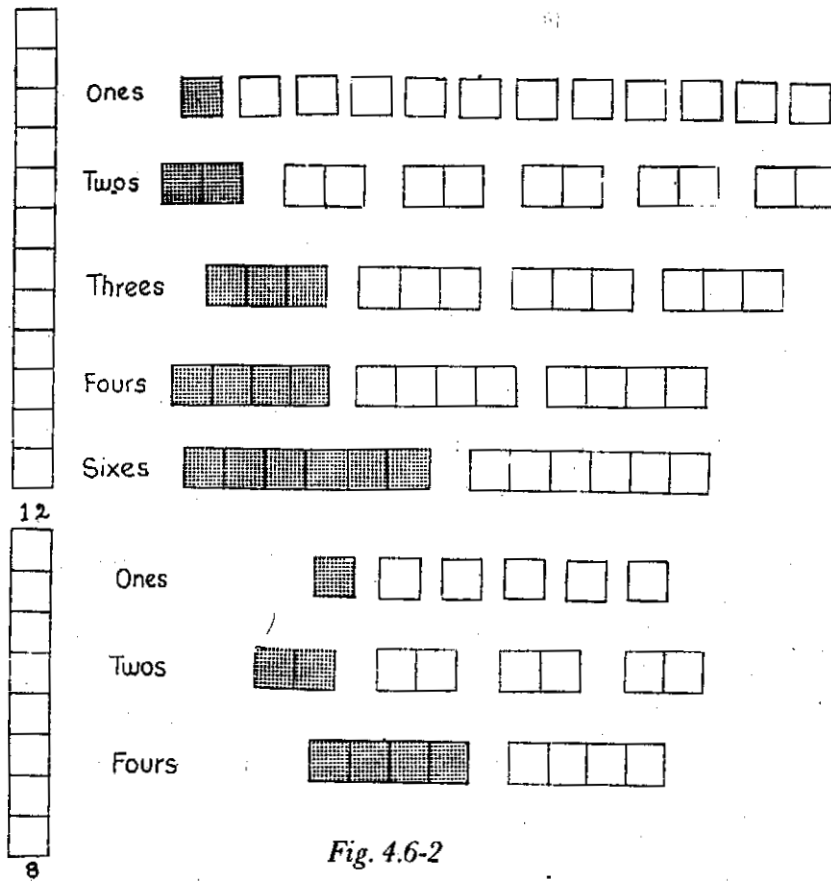

Fig. 4.6-2

**A. Relatively prime or coprime**

- B.** If two numbers have no common factors other than 1, then the two numbers are relatively prime or coprime.  
Two consecutive numbers are relatively prime.
- C.** Common objects, square ruled sheet.
- D.** Represent two numbers (less than ten) by collections of objects. Each can be arranged to show up in ones. Examine if either of them can be arranged to show up in groups with the same number. If it is not possible, then the two numbers are relatively prime.  
Take a square ruled sheet, cut out square strips to represent the two numbers chosen. Examine folding each of them such that the folded parts overlap in each and the folded parts in each have the same number of squares. If this is not possible except for the folded parts being single squares, the two numbers are relatively prime.  
Repeat this exploration with square slips representing consecutive numbers and observe that two consecutive numbers are relatively prime.
- E.** Only small numbers up to 12 can lend themselves to this kind of exploration. Once the concept is grasped, the traditional technique could be accepted with appreciation.

## UNIT V

### Basis of Divisibility Rules

- 5.1 Numbers as sums
- 5.2 Numbers as products
- 5.3 Numbers as sums of products
- 5.4 Divisors of dividends and their sums
- 5.5 Divisor of a number and the multiple of the number
- 5.6 Divisibility of higher units by five and ten
- 5.7 Divisibility of higher units by three and nine
- 5.8 Divisibility of higher units by two, four, and eight

#### 5.1

##### A. Numbers as sums

- B. Any number greater than 1 can be expressed as a sum of two other numbers (in natural number system).
- C. Common objects, square slips (of paper).
- D. Take a collection of objects and see if it can be split up into two smaller collections. Use this experience to give the number of the collection as the sum of numbers of two smaller collections. Use square slips also in the exploration. Repeat the exploration with other numbers and state your observations generally.

#### 5.2

##### A. Numbers as products

- B. Any number greater than 0 can be expressed as a product of two numbers. If a number is composite, it can be expressed as a product of two other numbers.
- C. Common objects, square slips (of paper) of the same size.
- D. Take a collection of objects and see if it can be arranged in only one row or a rectangular array with more than one row. In either case the number of the collection can be expressed as a product of two numbers (number of rows and number of objects in each row). Use square slips also in this exploration. Repeat this exploration with other numbers and state your observations generally.

### A. Numbers as sums of products

5.3

- B.** Any number (greater than 2) can be expressed as a sum of products of numbers. Any number having numerals with more than one digit can be expanded to show in particular as a sum of multiples of higher units.
- C.** Common objects,  $10 \times 10$  square sheets, 10 square strips, loose squares.
- D.** Take a collection of objects numbering more than 2 for convenience and see if the collection can be split up into smaller collections and each of these collections can be expressed as rectangular arrays. Use this experience to give the number of the collection as a sum of products. *Fig. 5.3-1*    *Fig. 5.3-2*  
Represent a two digit number, using 10 square strips and loose squares and express it as a sum of products.

Represent a three digit number, using  $10 \times 10$  square sheets, 10 square strips and loose squares and express the number as a sum of products.

From the experience with multi digit numbers, state your observation generally.

5.4

### A. Divisors, dividends and their sums

- B.** If two numbers have a common divisor, then the divisor divides also the sum of the two numbers.  
If a number divides a second number and the sum of the second number and a third number, the divisor number divides the third number also.
- C.** Square ruled sheet.
- D.** Cut out two rectangular arrays from the square ruled sheet to represent the second number and the third number such that the number of rows (or the number of squares in each row) is the same as the divisor number. Such rectangular arrays can be combined to form a bigger rectangular array, showing that the same divisor divides the sum of the numbers. Explore this with more rectangular arrays. Cut out a rectangular array such that the divisor is represented by the number of rows (or the number of squares in each row) the second number is represented by the number of squares in each row (or the number of rows). Without changing the number of rows, the rectangular array can be enlarged and the divisor will divide any enlarged rectangular array. Apportioning the part representing the second number, it is seen that the third number is also divisible by the divisor.





**A. Divisors of a number and the multiple of the number**

- B.** If a number divides a second number, it divides every multiple of the second number.
- C.** Square ruled sheet.
- D.** Cut out rectangular arrays, each of which represents a number such that the number of rows (or the number of squares in each row) is the same as the divisor. By combining any number of these rectangular arrays, the multiples of the second number are got and it is easily seen that each of these multiples is divisible by the divisor.

**A. Divisibility of higher units by 5 and 10**

- B.** Every higher unit is divisible by 5  
Every higher unit is divisible by 10
- C.** Spike abacus and beads  
Ten-square column paper abacus.
- D.** Represent any higher unit on an abacus and since each can be changed into ten immediate lower units, observe that any higher unit is divisible by 5 or 10.

**A. Divisibility of higher units by 3 and 9**

- B.** Predecessor of every higher unit is divisible by 3.  
Predecessor of every higher unit is divisible by 9.
- C.** Spike abacus and beads.  
Ten-square column paper abacus.
- D.** Represent the first higher unit ten on the abacus. Change it by putting ten units in units spike (or column). It is easily seen that ten ones cannot be distributed equally in 3 places or 9 places. But on removing 1 from ten ones, nine ones are left and the nine ones can be distributed equally in 3 places or 9 places. Observe that the predecessor of ten is divisible by 3 and 9. Represent the next higher unit hundred on the abacus. Change this by taking 9 tens and 10 ones. Again it is seen that by removing 1 one, 9 tens and 9 ones are left and these can be distributed equally in 3 or 9 places. Since 99 is 1 less than 100, the predecessor of 100 is divisible by 3 and 9. Consider still higher units and finding similar experience, it can be observed with enough confidence that the predecessor of any higher unit is divisible by 3 and 9.

### A. Divisibility of higher units by 2, 4, and 8

**B.** Any higher unit can be expressed as a multiple of ten. Since ten is divisible by 2, every higher unit is divisible by 2.

Ten is not divisible by 4, but hundred is divisible by 4. Every higher unit beyond 100 can be expressed as a multiple of hundred and so is divisible by 4. Ten is not divisible by 8; hundred is not divisible by 8, but thousand is divisible by 8. Every higher unit beyond 1000 can be expressed as a multiple of 1000 and so is divisible by 8.

**C.**  $10 \times 10$  square sheets, 10-square strips and loose squares.

**D.** Represent the higher unit *ten* by a ten-square strip. Explore if it can be distributed equally in 2 places. By changing it into ten ones, it is easily seen that the higher unit ten is divisible by 2. Observe that the higher unit ten and hence each higher unit beyond ten, being a multiple of ten, is divisible by 2.

Represent the higher unit *ten* by a ten-square strip. Explore if it can be distributed equally in 4 places, by changing it into lower units. Changing 1 ten into ten ones, it is easily seen that the higher unit ten cannot be distributed equally in four places.

Consider next the higher unit *hundred*. By changing it into ten tens, each of the four places will have 2 tens and 2 tens will be left. Changing the 2 tens left into 20 ones, each of the four places will have 5 ones more, showing thereby that the higher unit *hundred* is divisible by 4. Observe that higher unit *hundred* and hence each of the higher units beyond *hundred*, being a multiple of *hundred*, is divisible by 4. Proceeding on similar lines, observe that higher units *ten* and *hundred* are not divisible by 8 but the higher unit *thousand* and each higher unit beyond *thousand*, being a multiple of *thousand*, is divisible by 8.

**E.** Even without actual use of aids, these can be done by visualisation.

## UNIT VI

### From Whole to Part and Part to Whole

- 6.1 Whole and part
- 6.2 Naming parts
- 6.3 Equivalent fractions
- 6.4 Comparison of 'simple fractions'
- 6.5 The relation between whole numbers and 'simple fractions'
- 6.6 Addition and subtraction of 'simple fractions'—meaning and method
- 6.7 Multiplication of 'simple fractions'—meaning and method
- 6.8 'Simple fractions' and their reciprocals
- 6.9 'Division with simple fractions'
- 6.10 'Simple fractions' in decimal notation
- 6.11 Addition and subtraction of 'decimal fractions'
- 6.12 Multiplication of 'decimal fractions'—meaning and method
- 6.13 Division with 'decimal fractions'—meaning and method
- 6.14 'Fractions' and 'percentages'

6.1

#### A. Whole and part

- B. A set of discrete objects can be considered a whole or a part.  
A continuous object can be considered a whole or a part. There is nothing to be considered a whole or a part in absolute sense. Whole and part are relative.
- C. Paper (rectangular), seeds, bottle tops.
- D. Take a collection of seeds. This collection can be considered a whole. This can also be considered a part (of a whole), if it is assumed to have been taken from another collection. *Fig. 6.1-1*  
Take a sheet of paper. It can be considered a whole. It can also be considered a part (of a whole), if it is assumed to have been cut out from a larger paper. *Fig. 6.1-2*  
The sheet can also be considered to represent 2, or for that matter any whole number or any fractional number. *Fig. 6.1-3*

Observe that whole and part are not absolute but relative.

WHOLE AND PART

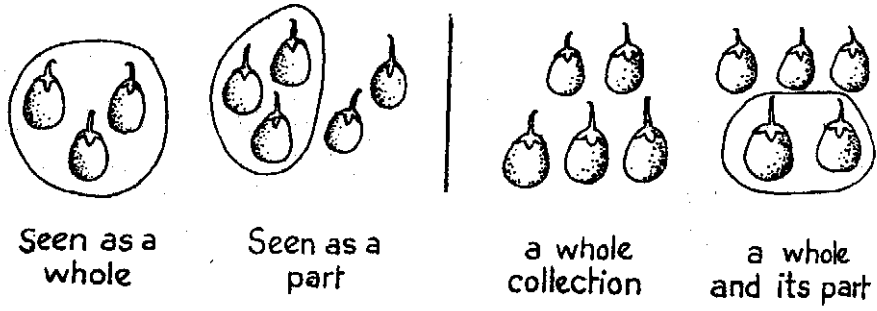

Fig. 6.1-1

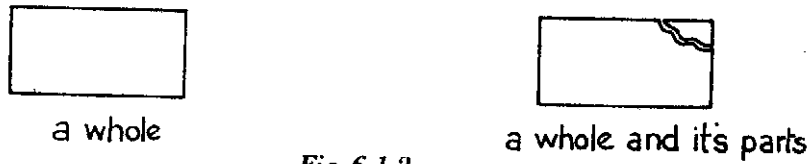
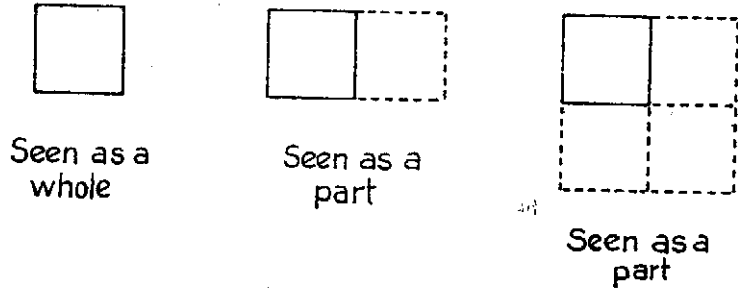

Fig. 6.1-2

Whole and part are relative

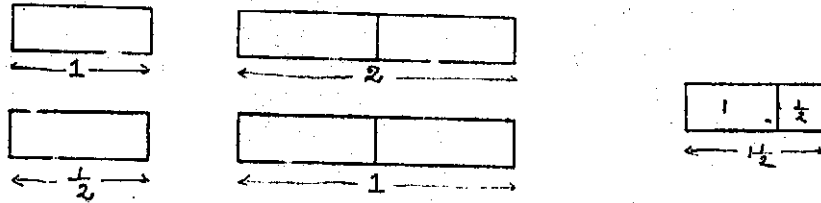

Fig. 6.1-3

**A. Naming parts**

- B.** A whole can be divided into unequal and equal parts. If a whole is divided into two equal parts, each part is half of the whole and written as a simple fraction  $\frac{1}{2}$  in which 1 is the numerator—the number of

times the part is taken and 2 the denominator—the kind of part considered depending on the number of equal parts into which the whole is divided.

A fraction is a relation that a part bears to the whole. Two fractions cannot be compared when they are from different 'wholes'.

If a whole is divided into four equal parts, each part is a quarter of the whole and written as a simple fraction  $\frac{1}{4}$ . If two of the parts or two quarters are considered, the simple fraction is  $\frac{2}{4}$ . If three of the parts or three quarters are considered, the simple fraction is  $\frac{3}{4}$ .

If a whole is divided into three equal parts, each part is a third of the whole and written as a simple fraction  $\frac{1}{3}$ . If two parts or two thirds are considered, the fraction is  $\frac{2}{3}$ .

If a number of line segments of the same length are joined to form a longer line segment, names of dividing marks depend on the way, the whole is fixed. Parts of a whole are less than a whole and they are given by proper (simple) fractions in each which the numerator is less than the denominator. If 'portions' taken are not less than a whole, they are given by improper (simple) fractions in which the numerators are equal to or greater than the denominator.

A simple fraction can be interpreted in three ways. For example consider  $\frac{2}{5}$ . It means (1) A whole is divided into 5 equal parts and 2

of the parts are taken, (2) 2 is divided by 5 or what part of 5 is 2? (3) A whole is divided into fifths and 2 of them are taken.

- C.** Seeds, thread, wire, paper (rectangular), paper (circular).

- D.** Take a collection of eight seeds. Divide the collection unequally, unequal parts may consist of 3 seeds and 5 seeds; 1 seed and 7 seeds. Divide the collection equally. Equal parts may each consist of 1 seed, 2 seeds or 4 seeds.

Take a collection of 12 seeds. Taking the collection as a whole, it can be divided into 2 equal parts. Then each part is half of the collection and it is made up of 6 seeds. The collection can also be divided into 4 equal parts each made up of 3 seeds. Two quarters  $\frac{2}{4}$  of the collection have 6 seeds each and three quarters  $\frac{3}{4}$  of the collection 9 seeds. The collection can also be divided into 3 equal parts in which case each part is a third of the collection and it is made up of 4 seeds. Two thirds of the collection have 8 seeds.

*Fig. 6.2-1*

Take a sheet of paper (rectangular). Fold it into two equal parts (ensured by perfect overlapping). Observe that each part is half of the whole and record  $\frac{1}{2}$ .

*Fig. 6.2-2*

Fold the paper into four equal parts (by folding it into two equal parts first and then folding it again into two equal parts, ensured by perfect overlapping each time. Observe that each part is a quarter of the whole and record  $\frac{1}{4}$ . Consider the portion made up of two equal parts and the portion is two quarters of the whole and record  $\frac{2}{4}$ .

Consider the portion made up of 3 equal parts and the portion is three quarters of the whole and record  $\frac{3}{4}$ . Observe that the whole can be considered 4 quarters and recorded  $\frac{4}{4}$  which is 1.

*Fig. 6.2-3*

Take a sheet of paper (rectangular). Fold it into 3 equal parts (by bringing the two opposite edges in such a way that the part from one edge is below the part from the opposite edge and ensuring perfect overlapping of the three parts)

*Fig. 6.2-4*

Observe that each part is a third of the whole and record  $\frac{1}{3}$ . If the portion consisting of two equal parts is taken, observe that the portion is two thirds of the whole and record  $\frac{2}{3}$ .

A COLLECTION AND ITS PARTS

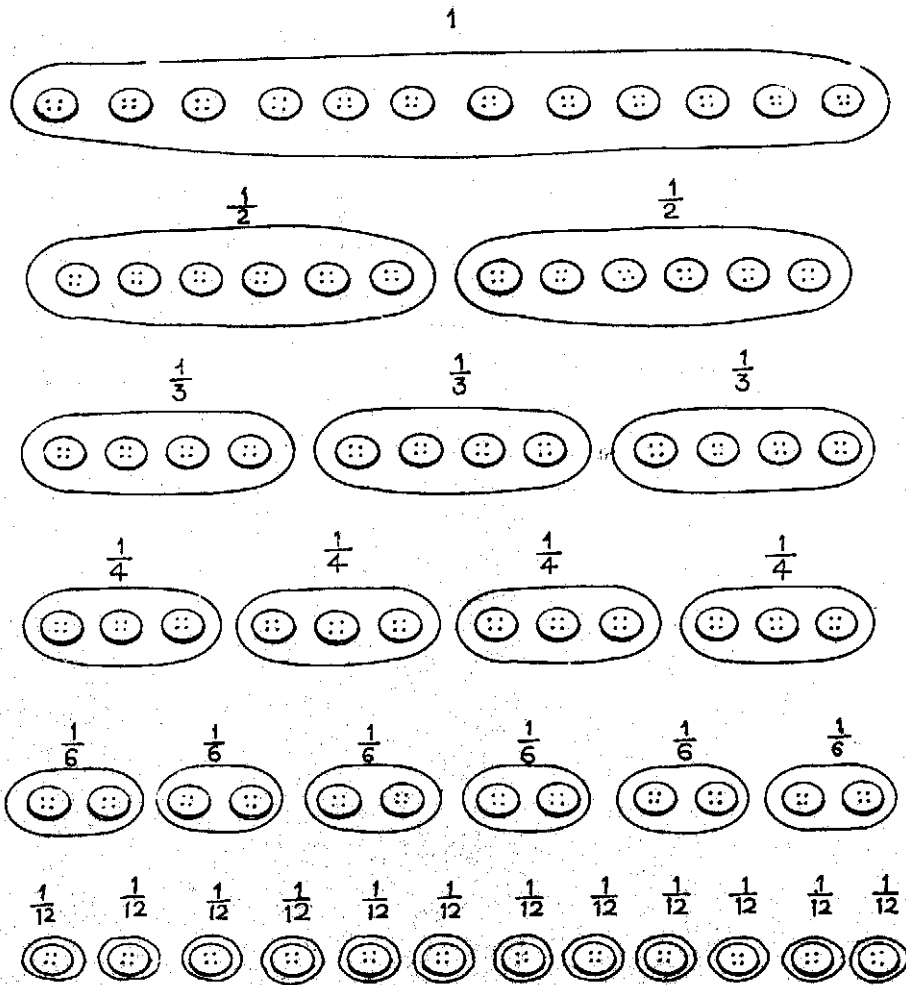

Fig. 6.2-1



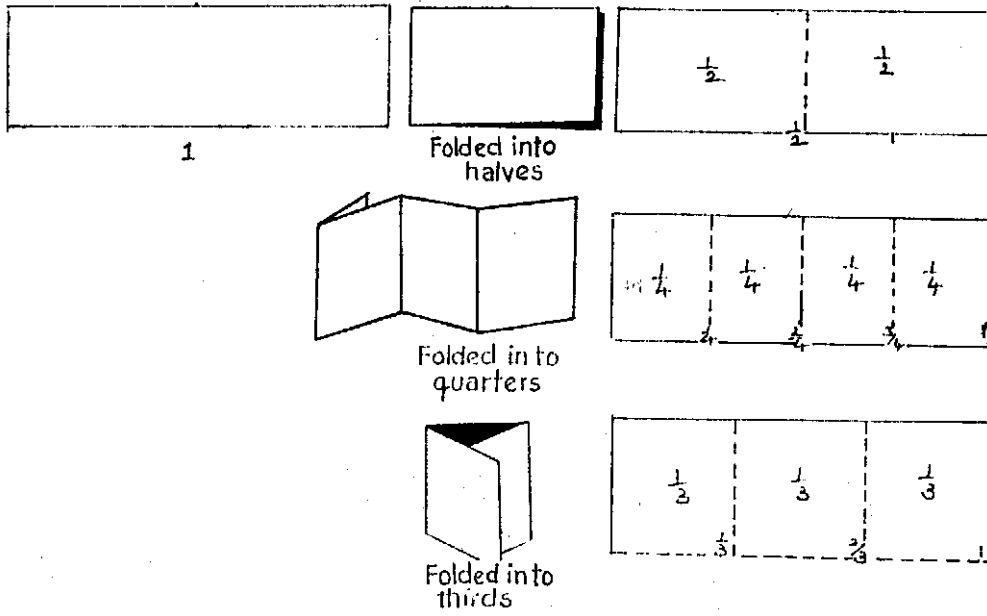

Fig. 6.2-4

Take six sticks (or wire pieces or thread pieces) of equal length. Put them end to end to form a line. Taking one piece as a whole, the stretch is 6 times the whole or 6 wholes. Taking two pieces together to form a whole, the stretch is 3 wholes; the first piece forms  $\frac{1}{2}$ , the two pieces form  $\frac{2}{2}$  and the three pieces form  $1\frac{1}{2}$  or  $\frac{3}{2}$ . Taking three pieces as a whole, the stretch is 2 wholes. The first piece forms  $\frac{1}{3}$ , the two pieces form  $\frac{2}{3}$ , the three pieces form  $\frac{3}{3}$  or 1; the four pieces together form  $1\frac{1}{3}$  or  $\frac{4}{3}$  and so on. Observe that

$$\frac{2}{2}, \frac{3}{2}, \text{ etc.}, \frac{3}{3}, \frac{4}{3} \text{ etc. are improper fractions and}$$

$$\frac{1}{2}, \frac{1}{3}, \frac{2}{3} \text{ etc. are proper fractions.}$$

Fig. 6.2-5

Take a double sheet of paper. Divide it into four equal parts. Take one sheet of paper (which is half the double sheet). Divide it into 4 equal parts. Observe that a quarter of the double sheet is two quarters of the single sheet. Observe that 2 divided by 4 is the same as 2 quarters. Fig. 6.2-6

Half of a paper has no particular shape. Some times overlapping can be tested only after cutting the two parts. Fig. 6.2-7 Fig. 6.2-8

Dividing 3 among 2 places.

*Discrete situation*

If 3 represents 3 discrete objects, then only one object can be placed in each of the two places and one object will be left.

*Continuous situation*

If 3 represents 3 continuous objects, then one object and half of an object can be placed in each of the two places and nothing will be left.

It can also be done in another way. Divide 3 objects into six half objects and distribute 3 half objects equally in each of the two places.

Fig. 6.2-9

- E. It is helpful to develop the skill to fold a paper to get 12 equal parts and 18 equal parts. Fold a paper into halves, again into thirds and again in to halves for division into 12 ( $2 \times 3 \times 2$ ) equal parts. Fig. 6.2-10 Fold a paper into halves, then into thirds again, into thirds to get 18 ( $2 \times 3 \times 3$ ) equal parts. This is one way. To get any number of parts, cut off the portion from the strip of squares, consisting of the required

# CHANGE OF WHOLE AND ITS PARTS

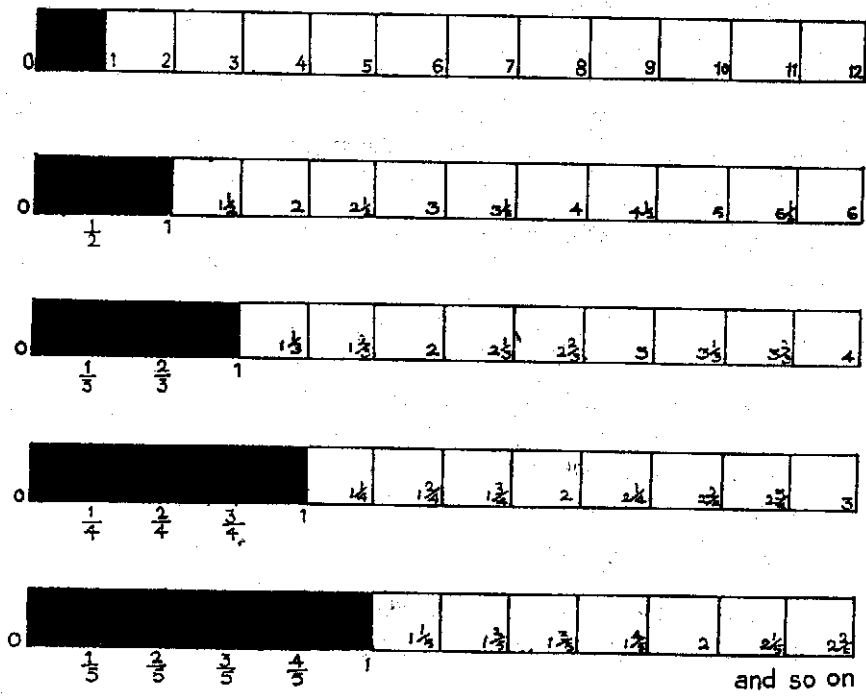

Fig. 6.2-5

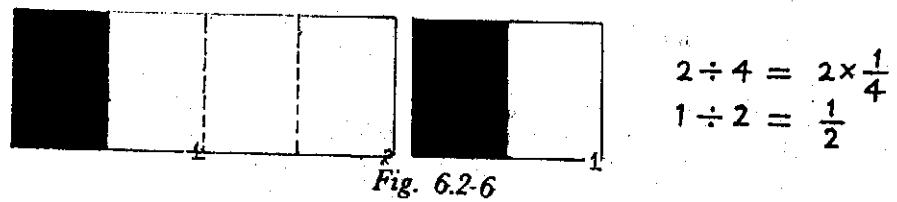
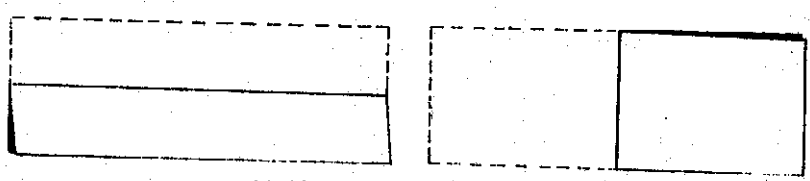
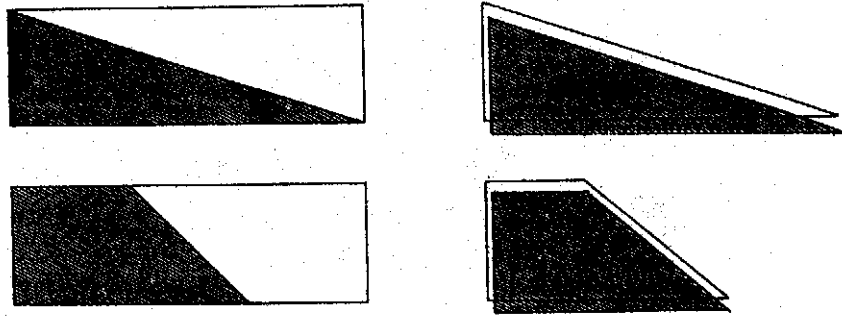

Fig. 6.2-6



Half by overlapping by folding

Fig. 6.2-7



Half by overlapping of cut outs

Fig. 6.2-8

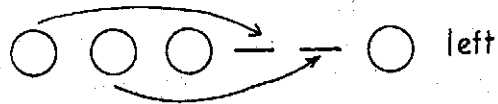

Halving  
in  
different  
ways

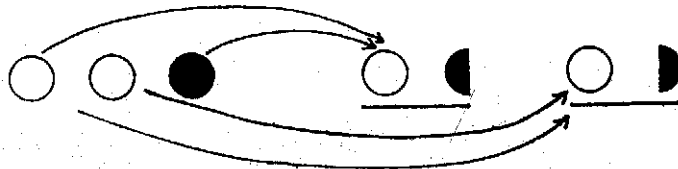

Fig. 6.2-9

FOLDING PAPER STRIP TO GET  
 $\frac{1}{6}$ 's AND  $\frac{1}{9}$ 's AND  $\frac{1}{18}$ 's

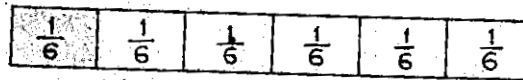
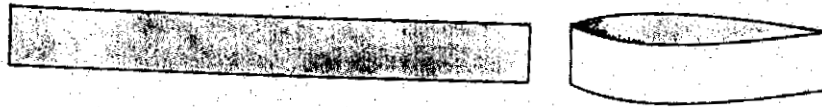

Fig. 6.2-10

number of parts and treat the cut off portion as a whole. Introducing solid objects like apple, banana etc. for teaching half, quarter etc. gives a distorted understanding of fraction, as two halves, four quarters etc. cannot be tested to be identical. *Remember we teach mathematics half and not market half and mummy half.* Introduction of fraction in semi concrete situation e.g. half the number of objects of different kind or sizes may follow later.

### 6.3

#### Equivalent fractions

- B.** A fractional number can be expressed in different fractional numerals.

Different fractional numerals representing the same fractional number are equivalent fractions.

By multiplying the numerator and the denominator of a fraction by the same natural number, an equivalent fraction is obtained.

By dividing the numerator and the denominator of a fraction by their common factor, an equivalent fraction is obtained.

- C.** Paper strips of the same length and width, seeds, graduated rulers.
- D.** *Take three paper strips of the same size. Fold the first paper strip into halves, the second into quarters, the third into eighths, place the strips one below the other lengthwise in proper alignment and compare the parts. Observe that half of a whole, 2 quarters of the whole and 4 eighths of the whole represent the same portion of the whole and so record.*

$$\frac{1}{2} = \frac{2}{4} = \frac{4}{8}$$

*Fig. 6.3-1*

*Take three paper strips of the same size. Fold the first into thirds, the second into sixths and the third into twelfths. Put the strips one below the other, lengthwise, in proper alignment and compare the parts. Observe that a third of a whole, two sixths of the whole and four twelfths of the whole are the same and so record:*

$$\frac{1}{3} = \frac{2}{6} = \frac{4}{12}$$

*Fig. 6.3-2*

Since paper strips taken are of the same length and width, they represent the same whole. So collect the strip divided into halves, the strip divided into fourths, the strip divided into sixths, the strip divided into eighths and the strip divided into twelfths and place the strips one below the other lengthwise in proper alignment and compare the parts. Observe now that,

$$\frac{1}{2} = \frac{3}{6} = \frac{4}{8} = \frac{6}{12}$$

$$\frac{1}{4} = \frac{2}{8} = \frac{3}{12}$$

*Fig. 6.3-3*

### Equivalent fractions from a whole

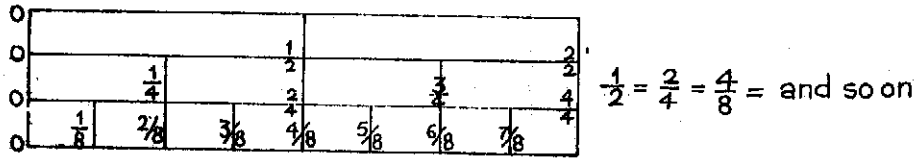

Fig. 6.3-1

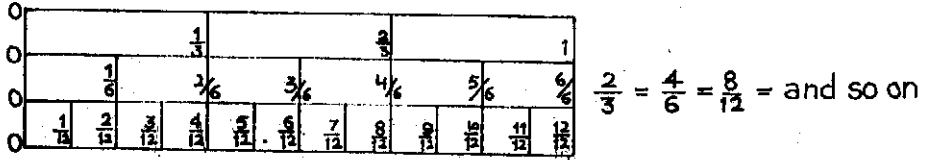

Fig. 6.3-2

### EQUIVALENT FRACTIONS

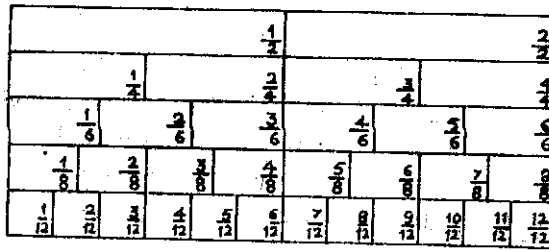

Fig. 6.3-3

From the pattern of equivalent fractions, observe that everytime the numerator and the denominator are multiplied by the same number (natural) or divided by their common factor, an equivalent fraction is obtained.

*Graduated ruler*

Take a graduated ruler. Consider the portion marked 12 (on *inch side* for convenience) as a whole. Then the 12 divisions become parts of the whole, and get marked as

$$\frac{1}{12}, \frac{2}{12}, \frac{3}{12} \text{ to } \frac{12}{12}$$

Divisions beyond 12 will get re-marked as  $\frac{13}{12}, \frac{14}{12}$  and so on

Since the whole can also be considered to be made up of 6 equal parts, re-mark the divisions as follows

$$2 \rightarrow \frac{1}{6}$$

$$4 \rightarrow \frac{2}{6}$$

$$6 \rightarrow \frac{3}{6}$$

$$8 \rightarrow \frac{4}{6}$$

$$10 \rightarrow \frac{5}{6}$$

$$12 \rightarrow \frac{6}{6}$$

Any division beyond 12 will get re-marked as follows

$$14 \rightarrow \frac{7}{6}, 16 \rightarrow \frac{8}{6} \text{ and so on.}$$

Since the whole can be considered to be made up of 3 equal parts, re-mark the divisions as follows:

$$4 \rightarrow \frac{1}{3}$$

$$8 \rightarrow \frac{2}{3}$$

$$12 \rightarrow \frac{3}{3}$$

Any divisions beyond 12 will get re-marked as follows

$$16 \rightarrow \frac{4}{3}, 20 \rightarrow \frac{5}{3} \text{ and so on. } \text{Fig. 6.3-4}$$



Since the whole can also be considered to be divided into 4 equal parts, re-mark the divisions as follows:

$$3 \xrightarrow{\frac{1}{4}} 6 \xrightarrow{\frac{2}{4}} 9 \xrightarrow{\frac{3}{4}} 12 \xrightarrow{\frac{4}{4}}$$

And divisions beyond 12 will get remarked as follows:

$$15 \xrightarrow{\frac{5}{4}}, 18 \xrightarrow{\frac{6}{4}}, \text{ etc.}$$

Since the whole can also be considered to be made up of 2 equal parts, re-mark the divisions follows:

$$6 \xrightarrow{\frac{1}{2}}$$

$$12 \xrightarrow{\frac{2}{2}}$$

And divisions beyond 12 will get re-marked as

$$18 \xrightarrow{\frac{3}{2}}, 24 \xrightarrow{\frac{4}{2}} \text{ and so on.}$$

Observe that 1 half of a whole, 2 quarters of the whole, 2 sixths of the whole and twelfths of the whole show the same portion of the whole and so they are equal and record

$$\frac{1}{2} = \frac{2}{4} = \frac{3}{6} = \frac{4}{12}$$

Pick up more such equal portions and record

$$\frac{1}{6} = \frac{2}{12}, \frac{1}{3} = \frac{2}{6} = \frac{3}{12}, \frac{1}{4} = \frac{3}{12}$$

Observe also that

$$\frac{3}{2} = \frac{6}{4} = \frac{9}{6} = \frac{18}{12} \text{ and so on.}$$

Fig. 6.3-5

*Discrete situation*

Take twelve objects. Consider them to form a whole. Study equivalent fractions as above.

- E. Multiplying the numerator and denominator even by fractional numbers to get equivalent fractions is not considered at this stage.

## 6.4

### A. Comparison of 'simple fractions'

- B. Of two like fractions (the fractions with the same denominator), the one having the greater numerator is greater.

Of two unit fractions (the fractions with 1 in the numerator) the one having the greater denominator is smaller.

If two fractions have the same numerator and different denominators, the one having the greater denominator is smaller.

Any improper fraction is greater than 1 as well as any proper fraction.

1 is greater any proper fraction.

To compare two unlike fractions (fractions having different de-

1	2	3	4	5	6	7	8	9	10	11	12	13	14	15	16	17	18	19	20	21	22	23	24	25	26	27	28	29	30	31	32		
$\frac{1}{32}$	$\frac{2}{32}$	$\frac{3}{32}$	$\frac{4}{32}$	$\frac{5}{32}$	$\frac{6}{32}$	$\frac{7}{32}$	$\frac{8}{32}$	$\frac{9}{32}$	$\frac{10}{32}$	$\frac{11}{32}$	$\frac{12}{32}$	$\frac{13}{32}$	$\frac{14}{32}$	$\frac{15}{32}$	$\frac{16}{32}$	$\frac{17}{32}$	$\frac{18}{32}$	$\frac{19}{32}$	$\frac{20}{32}$	$\frac{21}{32}$	$\frac{22}{32}$	$\frac{23}{32}$	$\frac{24}{32}$	$\frac{25}{32}$	$\frac{26}{32}$	$\frac{27}{32}$	$\frac{28}{32}$	$\frac{29}{32}$	$\frac{30}{32}$	$\frac{31}{32}$			
$\frac{1}{16}$		$\frac{2}{16}$		$\frac{3}{16}$		$\frac{4}{16}$		$\frac{5}{16}$		$\frac{6}{16}$		$\frac{7}{16}$		$\frac{8}{16}$		$\frac{9}{16}$		$\frac{10}{16}$		$\frac{11}{16}$		$\frac{12}{16}$		$\frac{13}{16}$		$\frac{14}{16}$		$\frac{15}{16}$		$\frac{16}{16}$			
$\frac{1}{8}$	$\frac{1}{8}$		$\frac{2}{8}$		$\frac{3}{8}$		$\frac{4}{8}$		$\frac{5}{8}$		$\frac{6}{8}$		$\frac{7}{8}$		$\frac{8}{8}$		$\frac{9}{8}$		$\frac{10}{8}$		$\frac{11}{8}$		$\frac{12}{8}$		$\frac{13}{8}$		$\frac{14}{8}$		$\frac{15}{8}$		$\frac{16}{8}$		
$\frac{1}{4}$	$\frac{1}{4}$	$\frac{1}{4}$		$\frac{2}{4}$		$\frac{3}{4}$		$\frac{4}{4}$		$\frac{5}{4}$		$\frac{6}{4}$		$\frac{7}{4}$		$\frac{8}{4}$		$\frac{9}{4}$		$\frac{10}{4}$		$\frac{11}{4}$		$\frac{12}{4}$		$\frac{13}{4}$		$\frac{14}{4}$		$\frac{15}{4}$		$\frac{16}{4}$	
$\frac{1}{2}$	$\frac{1}{2}$		$\frac{2}{2}$		$\frac{3}{2}$		$\frac{4}{2}$		$\frac{5}{2}$		$\frac{6}{2}$		$\frac{7}{2}$		$\frac{8}{2}$		$\frac{9}{2}$		$\frac{10}{2}$		$\frac{11}{2}$		$\frac{12}{2}$		$\frac{13}{2}$		$\frac{14}{2}$		$\frac{15}{2}$		$\frac{16}{2}$		
$\frac{1}{1}$																																	

Fixing fractions with respect to a whole

Fig. 6.3-4

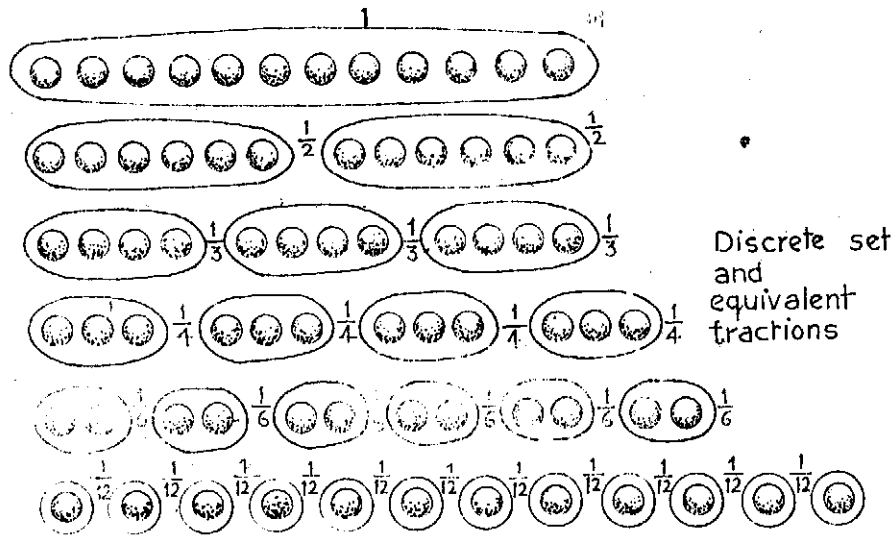

Fig. 6.3-5

nominators) they are changed into like fractions (by using the rule for getting equivalent fractions)

If a fraction A is greater than a fraction B and the fraction B is greater than the fraction C, then the fraction A is greater than the fraction C.

- C. Paper strips of the same length and width graduated rulers, seeds.  
 D. Take paper strips folded into halves, thirds, fourths and eighths (by bringing breadthwise edges together. Put them one below the other, lengthwise, in proper alignment.

Observe  $\frac{1}{2}$  of a whole is greater than  $\frac{1}{3}$  of the whole,  $\frac{1}{3}$  of the whole is greater than  $\frac{1}{4}$  of the whole;  $\frac{1}{4}$  of the whole is greater than  $\frac{1}{8}$  of the whole and record

$$\frac{1}{2} > \frac{1}{3} > \frac{1}{4} > \frac{1}{8}$$

Fig. 6.4-1

Use the graduated ruler with 12 units (inches) considered as a whole and the divisions in it suitably re-named as explained in 4.3 and shown below Fig. 6.4-2

Observe that the inequalities of unlike fractions are determined by looking up for their equivalent like fractions

$$\frac{3}{4} > \frac{2}{3} \quad \frac{9}{12} > \frac{8}{12}$$

Observe that to compare unlike fractions, their respective corresponding equivalent and like fractions are to be determined. Observe that any improper fraction is not less than 1 and any proper fraction. Also 1 is greater than any proper fraction. Take a collection of 12 seeds and treat the collection as a whole and mark out the fractional parts. See the picture below.

As before observe the inequalities

$$\frac{1}{2} (6 \text{ seeds}) > \frac{1}{3} (4 \text{ seeds}) \text{ and so on. Fig. 6.4-3}$$

6.5

### A. The relations between whole numbers and 'simple fractions'

- B. A simple fraction is a whole number divided by a natural number. The dividend becomes the denominator and the divisor the numerator when the meaning of division is extended.

A natural number does not always divide a natural number perfectly (or exactly to give the remainder zero) whereas a fractional number always divides a fractional number perfectly (or exactly to give the remainder zero).

Every whole number can be considered to be a fractional number, whereas every fractional number cannot be considered a whole number.

When the numerator is (on integral) a multiple of the denominator, the fractional number represents a whole number.

# ORDERING PARTS OF THE, SAME WHOLE

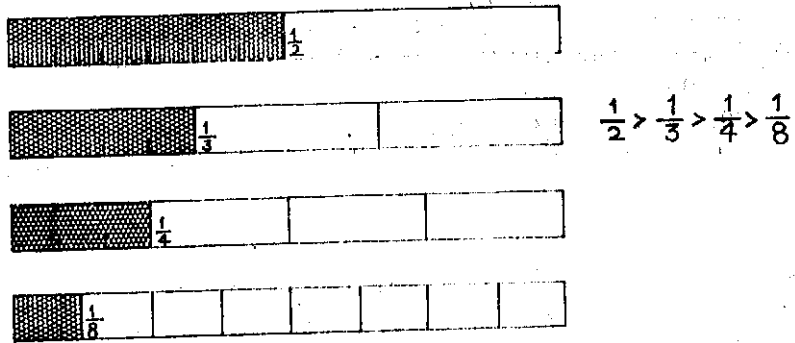
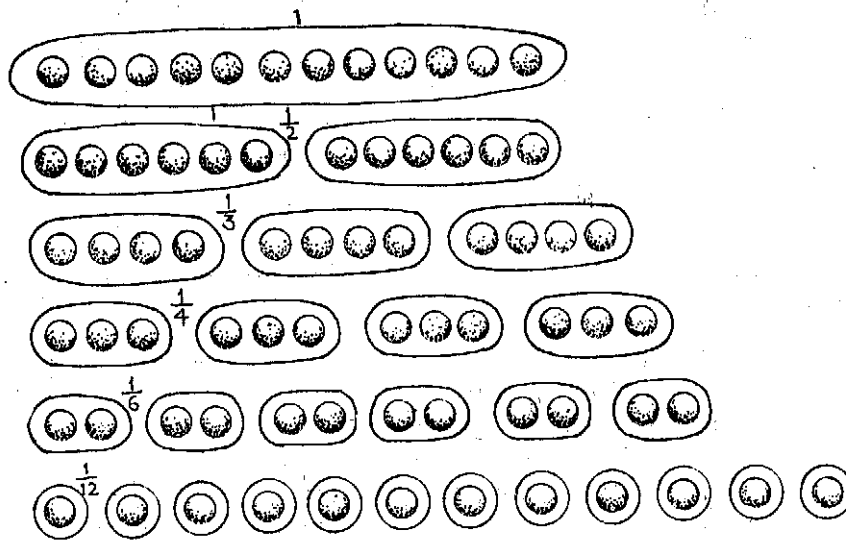

Fig. 6.4-1

Order of unit fractions



$$1 > \frac{1}{2} > \frac{1}{3} > \frac{1}{4} > \frac{1}{6} > \frac{1}{12}$$

Fig. 6.4-2

# ORDER OF UNIT FRACTIONS

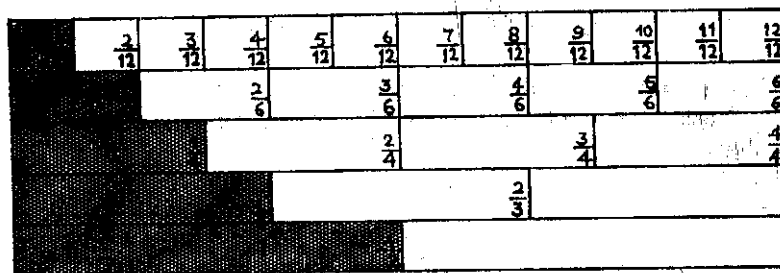

$$\frac{1}{12} < \frac{1}{6} < \frac{1}{4} < \frac{1}{3} < \frac{1}{2}$$

Fig. 6.4-3

An improper fraction can be written as a mixed number consisting of wholes and fractional parts.

- C. Seeds, paper strips, graduated rulers.  
 D. Take the graduated ruler with its 12 units (cm) considered as a whole and the divisions re-marked.

Observe that 1 is marked as

$$\frac{12}{12}, \frac{6}{6}, \frac{4}{4}, \frac{3}{3}, \frac{2}{2}$$

2 as

$$\frac{24}{12}, \frac{12}{6}, \frac{8}{6}, \frac{6}{3}, \frac{4}{2}$$

and so on.

Observe that 0 is marked as

$$\frac{0}{12}, \frac{0}{6}, \frac{0}{4}, \frac{0}{3}, \frac{0}{2}$$

and so on showing that whole numbers (including 0) are fractional numbers. In each observe that the numerator is a multiple of the denominator.

Observe also that every fractional number is not a whole number.

## 6.6

### A. Addition and subtraction of simple fractions-meaning and method.

- B. Two like fractions can be added and the sum is a like fraction of the same kind with its numerator equal to the sum of the numerators of the two like fractions. Two unlike fractions cannot be added as they are. They should be first changed to like fractions and then added.

Subtracting a fraction from its greater like fraction yields a like fraction with its numerator equal to the difference of the numerators of the two like fractions.

To subtract a fraction from its greater unlike fraction, change them first into like fractions and do the subtraction of a like fraction from its greater like fraction.

- C. Paper strips, seeds and a pair of graduated rulers.  
 D. Take paper strips divided into halves, quarters, eights. Put them one below the other in proper alignment. From the same paper strip, observe that

$$\frac{1}{2} + \frac{1}{2} = 1, \quad \frac{1}{4} + \frac{1}{4} = \frac{1}{2}, \quad \frac{1}{4} + \frac{1}{4} + \frac{1}{4} = \frac{3}{4},$$

$$\frac{1}{8} + \frac{3}{8} = \frac{4}{8} \text{ and so on.}$$

Observe like fractions are in the same strip and so addition is easily done.

To add  $\frac{1}{4} + \frac{1}{8}$  observe that  $\frac{1}{4} = \frac{2}{8}$  and so

$$\frac{1}{4} + \frac{1}{8} = \frac{2}{8} + \frac{1}{8} = \frac{3}{8}$$

So to add unlike fractions, observe that unlike fractions are converted to like fractions first. *Fig. 6.6-1 Fig. 6.6-2*

Subtraction of one like fraction from another like fraction is done on the same strip and subtraction of one unlike fraction from another unlike fraction is done after finding their equivalent like fractions.

*Fig. 6.6-3*

Use seeds to do the subtraction of a like fraction from a greater like fraction and the subtraction of an unlike fraction from a greater unlike fraction. *Fig. 6.6-4*

In doing addition and subtraction with fractional numbers, use of a pair of graduated rulers with say 12 units (inches) considered as a whole and the divisions re-marked is similar to the use of a pair of graduated rulers in doing addition and subtraction with whole numbers. *Fig. 6.6-5*

- E. Addition and subtraction of mixed fractions are not covered as they can be converted into improper fractions. Even otherwise these operations with mixed fractions can be done easily.

6.7

### A. Multiplication of simple fractions— meaning and method.

- B. A fractional part of a fractional part gives the product of the two fractions. The product of any two simple fractions (like or unlike) is a simple fraction with its numerator equal to the products of the numerators of the two simple fractions and its denominator equal to the product of the denominators of the two simple fractions.
- C. Paper strips, papers, transparent square papers of the same size, objects, graduated rulers.
- D. Take paper strips divided into halves, quarters, eighths. Find half of half part of the strip. Observe that it is simply a quarter of the same strip and so read and record half of half of a whole is quarter of the whole. Observe that multiplication is involved and so write

$$\frac{1}{2} \text{ of } \frac{1}{2} = \frac{1}{2} \times \frac{1}{2} = \frac{1}{4} \quad \text{Fig. 6.7-1}$$

Make more observations:

$\frac{1}{2}$  of  $\frac{2}{4}$  is  $\frac{1}{4}$  or  $\frac{2}{8}$  and  $\frac{1}{4}$  and  $\frac{2}{8}$  are equivalent fractions. So:

$$\frac{1}{2} \text{ of } \frac{2}{4} = \frac{2}{8} \text{ or } \frac{1}{4} \quad \text{and so on}$$

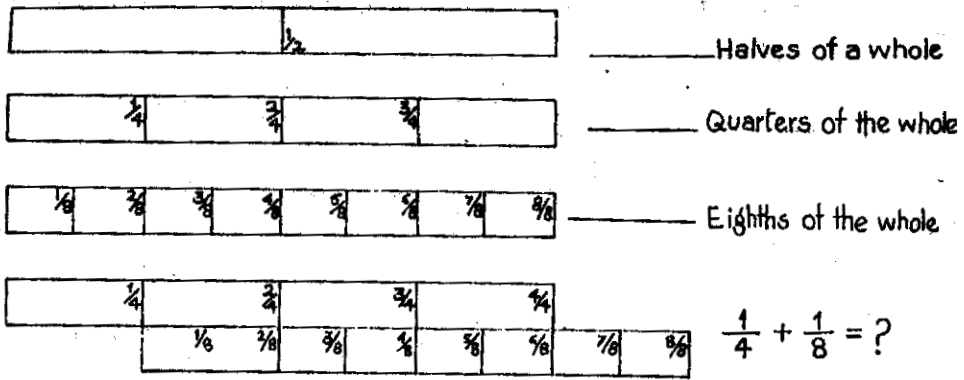

Fig. 6.6-1

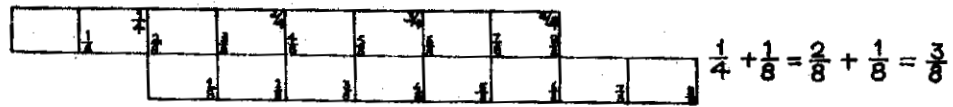

Fig. 6.6-2

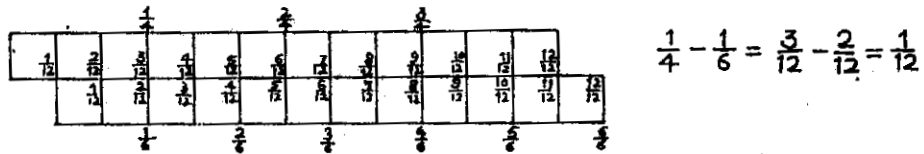
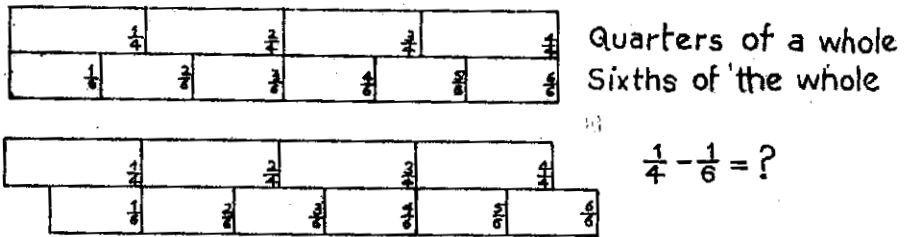

Fig. 6.6-3

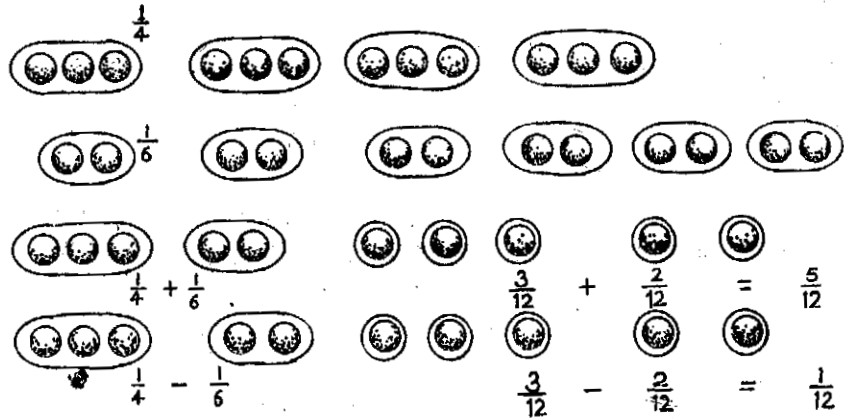
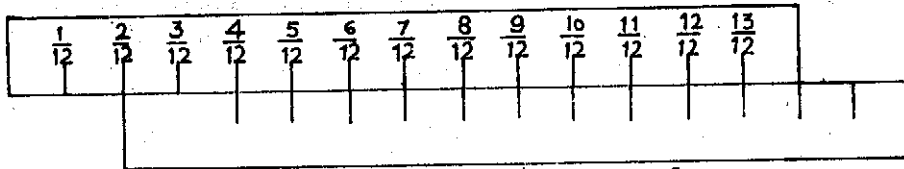
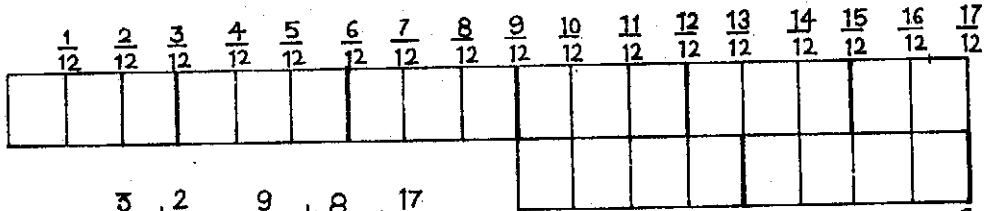

Fig. 6.6-4



$$\frac{2}{12} + \frac{1}{12} = \frac{3}{12} \text{ etc. } \frac{3}{12} - \frac{1}{12} = \frac{2}{12}$$



$$\frac{3}{4} + \frac{2}{3} = \frac{9}{12} + \frac{8}{12} = \frac{17}{12}$$

$$\frac{3}{4} - \frac{2}{3} = \frac{9}{12} - \frac{8}{12} = \frac{1}{12}$$

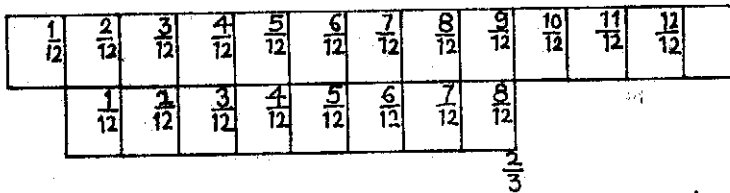
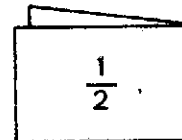
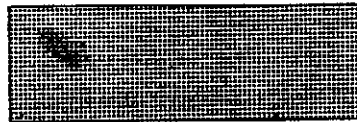

Fig. 6.6-5

### MULTIPLICATION OF FRACTIONS BY PAPER FOLDING



Getting half of a half of the whole



Fig. 6.7-1



Take papers of the same size (rectangular). Fold a paper into halves and find  $\frac{1}{3}$  of a half portion by folding that portion as above and observe and state what part of the whole is  $\frac{1}{3}$  of  $\frac{1}{2}$ . Fig. 6.7-2

Also fold a paper into thirds and  $\frac{1}{2}$  of a third portion by folding that portion alone and observe and state what part of the whole is  $\frac{1}{2}$  of  $\frac{1}{3}$ .

Fig. 6.7-3

Observe  $\frac{1}{3}$  of  $\frac{1}{2}$  of a whole and  $\frac{1}{2}$  of  $\frac{1}{3}$  of the whole give  $\frac{1}{6}$  of

the whole and write.

$$\frac{1}{3} \times \frac{1}{2} = \frac{1}{2} \times \frac{1}{3} = \frac{1}{6}$$

With transparent square papers folded to have creases to show respectively halves, thirds, quarters, sixths, eighths, multiplication of two fractions with denominators 2, 3, 6 and 8 can be easily obtained by choosing the appropriate pair of transparent squares and putting them criss cross against light, the product can be read off by the common regions of two portions of the whole.

Use the graduated ruler with 12 units (cm) taken as a whole and the divisions re-marked.

Observe that  $\frac{1}{2}$  of  $\frac{1}{4}$  is  $\frac{1}{8}$ , read and record  $\frac{1}{2} \times \frac{1}{4} = \frac{1}{8}$ . Fig. 6.7-4

Observe that  $\frac{1}{2}$  of  $\frac{2}{3}$  is  $\frac{2}{6}$  or  $\frac{1}{3}$ ,  $\frac{2}{3}$  of  $\frac{3}{4}$  is  $\frac{6}{12}$  or  $\frac{1}{2}$ ,  $\frac{3}{4}$  of  $\frac{5}{3}$  is  $\frac{15}{12}$  or  $\frac{5}{4}$  and so on

Take seven collections of 24 seeds each and consider each collection as a whole. Divide one into groups of 12 seeds each, then another into groups of 8 seeds each, then another into groups of 6 seeds each, then another into groups of 4 seeds each, then another into groups of 3 seeds each, then another into groups of 2 seeds each and finally the last into groups of 1 seed each, noting each time the fractions of the whole collection the groups represent.

Observe  $\frac{1}{2}$  of  $\frac{1}{4}$  is  $\frac{1}{8}$  ( $\because \frac{1}{2}$  of  $\frac{1}{4}$  is  $\frac{1}{2}$  of 6 or 3 which is  $\frac{1}{8}$ )

$\frac{2}{3}$  of  $\frac{5}{8}$  is  $\frac{10}{24}$  or  $\frac{5}{12}$  ( $\frac{2}{3}$  of  $\frac{5}{8}$  or  $\frac{2}{3}$  of 15 or 10 which is  $\frac{10}{24}$  or  $\frac{5}{12}$ ) Fig. 6.7-5

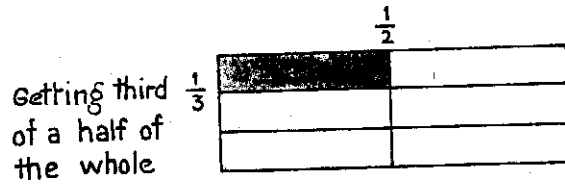
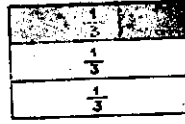
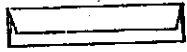

$$\frac{1}{3} \times \frac{1}{2} = \frac{1}{6}$$

Fig. 6.7-2

MULTIPLICATION OF FRACTIONS BY PAPER FOLDING

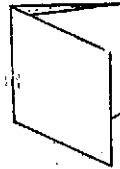

Getting thirds of a whole

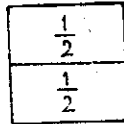
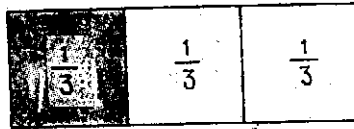

Getting half of a third of the whole

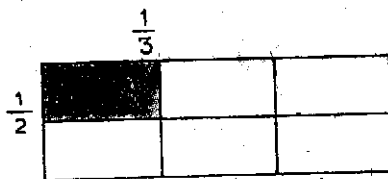

$$\frac{1}{2} \times \frac{1}{3} = \frac{1}{6}$$

Fig. 6.7-3

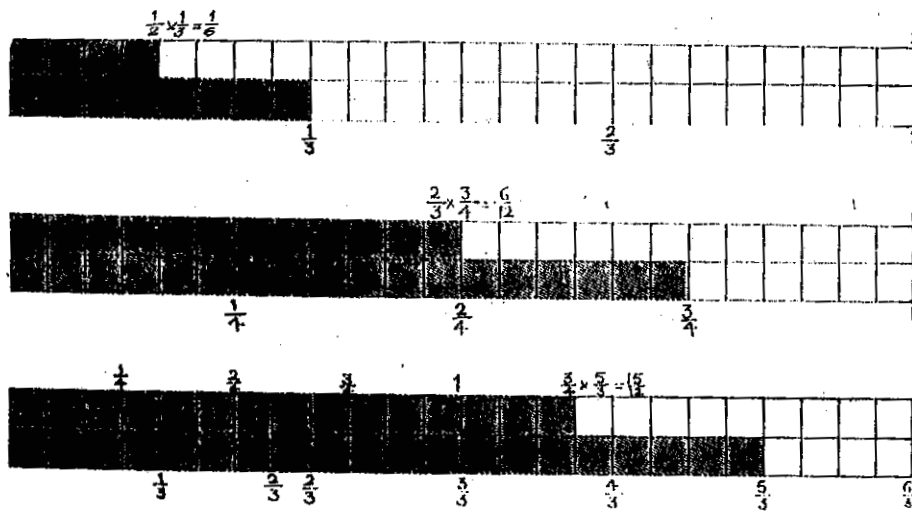

Fig. 6.7-4

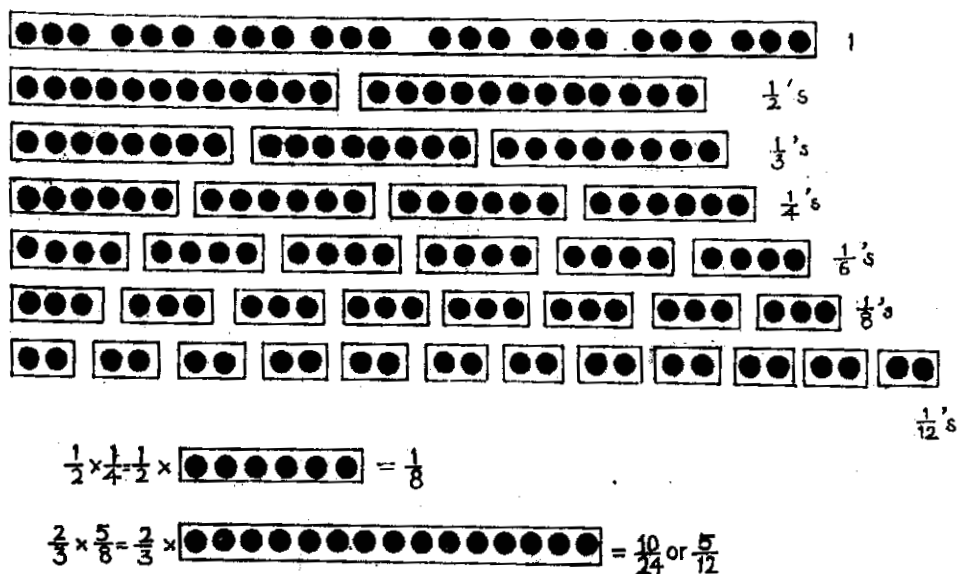

Fig. 6.7-5

- E. Multiplication of two mixed numbers is not covered, as mixed numbers can be converted simple into improper fractions.

6.8

**A. Simple fractions and their reciprocals**

- B. Each fraction, except zero, has a reciprocal. The product of a fraction ( $\neq 0$ ) multiplied by its reciprocal is equal to 1.  
The reciprocal of a proper fraction is an improper fraction ( $\neq 1$ ) and vice versa. The reciprocal of a natural number is a unit fraction. Zero has no reciprocal. The reciprocal of 1 is itself.
- C. Paper, graduated ruler, objects.
- D. Take a double sheet of paper. Let it represent 2. Take half of the double sheet. Observe that  $\frac{1}{2}$  of 2 is the same as one sheet. So

$$\frac{1}{2} \times 2 = 1. \quad \text{Fig. 6.8-1}$$

Take a sheet of paper. Let it represent  $1\frac{1}{2}$  or  $\frac{3}{2}$ . Mark the whole. Take  $\frac{2}{3}$  of the sheet and observe that  $\frac{2}{3}$  of  $\frac{3}{2}$  is the whole marked out. So

$$\frac{2}{3} \times \frac{3}{2} = 1 \quad \text{Fig. 6.8-2}$$

Also take  $\frac{2}{3}$  of a sheet and find  $\frac{3}{2}$  of that portion.

Observe that what is got is the same as the full portion of the sheet. So

$$\frac{3}{2} \times \frac{2}{3} = 1. \quad \text{Fig. 6.8-3}$$

Observe that for every fraction ( $\neq 0$ ), there is another fraction such that their product is equal to the whole. In other words, each fraction ( $\neq 0$ ) has a reciprocal. Observe also that the reciprocal of a natural number is a unit fraction and the reciprocal of a unit fraction is a natural number.

Take a graduated ruler with 12 units (cm) taken as a whole and the divisions re-marked.

Observe that  $\frac{3}{4}$  of  $\frac{4}{3}$  is  $\frac{12}{12}$  or 1,  $\frac{3}{2}$  of  $\frac{2}{3}$  is  $\frac{6}{6}$  or 1

and so on

*Fig. 6.8-4*

A (Non zero) FRACTIONAL NUMBER X ITS RECIPROCAL  
=UNITY

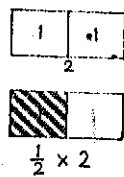
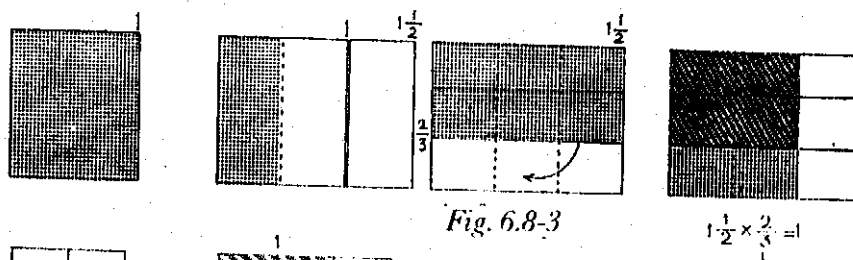

*Fig. 6.8-1*

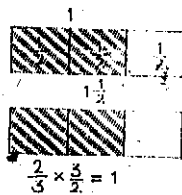

*Fig. 6.8-2*

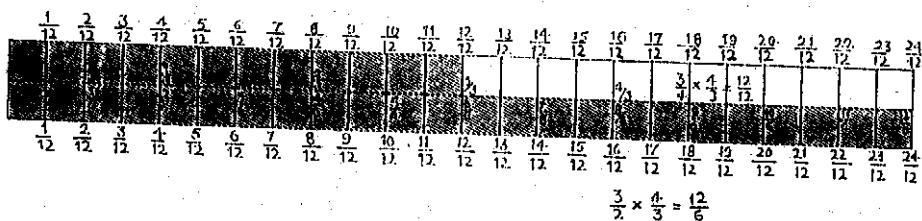

*Fig. 6.8-4*

Take five collections of 12 objects each. Consider the collection as a whole and divide one of it into groups of 6, then another into groups of 4, then another into groups of 3, then another into groups of 2, then the last into groups of 1 and marking in each case of grouping to show what part of the whole is each group.

Observe that

Observe that  $2 \times \frac{1}{2} = 1$  (or  $2 \times 6 = 12$ ) and also  $\frac{1}{2} \times 2 = 1$  (or  $\frac{1}{2} \times 24 = 12$ ) and so on. *Fig. 6.8-5*

Also observe that

$\frac{3}{4} \times \frac{4}{3} = 1$  ( $\frac{3}{4} \times 16 = 12$ ) and  $\frac{4}{3} \times \frac{3}{4} = 1$  ( $\frac{4}{3} \times 9 = 12$ )

## 6.9

### A. Division with simple fractions—meaning and method

- B. To divide a fraction by another, multiply the first fraction by the reciprocal of the second fraction. Division by a natural number is the same as multiplication by its reciprocal.
- C. Paper strips of the same length and width, objects.
- D. Take four strips. Keep one without folding. Fold the second one into two equal parts, the third one into three equal parts, the fourth one into four equal parts. Keep the whole strip (without folding). Keep below it in proper alignment the strip showing halves. Observe that there are two halves in a whole, read and record

$$1 \div \frac{1}{2} = 2. \quad \text{Fig. 6.9-1}$$

Keep the whole strip (without folding). Keep below it in proper alignment the strip showing thirds.

Observe that there are 3 thirds in a whole, read and record

$$1 \div \frac{1}{3} = 3. \quad \text{Fig. 6.9-2}$$

Take the strip showing halves. Keep below it in proper alignment the strip showing thirds.

The excess portion beyond  $\frac{1}{3}$  and  $\frac{1}{2}$  is half of  $\frac{1}{3}$  found by folding or looking for strips with proper subdivision. Observe that there are  $1\frac{1}{2}$  or  $3/2$  thirds in a half, read and record.

$$\frac{1}{2} \div \frac{1}{3} = \frac{3}{2} \text{ or } 1\frac{1}{2} \quad \text{Fig. 6.9-3}$$

(Observe 1 represents one  $\frac{1}{3}$  and  $\frac{1}{2}$  represents half of  $\frac{1}{3}$ )

Observe also that a third or  $\frac{1}{3}$  is  $2/3$  of a half, read and record.

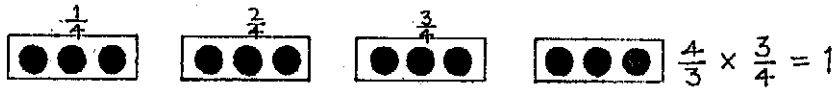
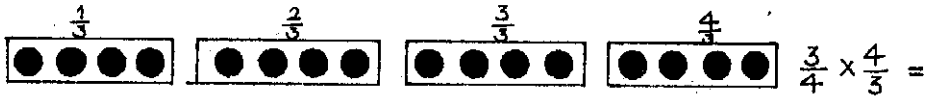

Fig. 6.8-5

### DIVISION BY FRACTIONAL NUMBER



$$1 \div \frac{1}{2} = 2$$

Fig. 6.9-1

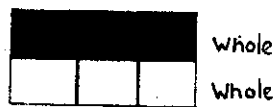

$$1 \div \frac{1}{3} = 3$$

Fig. 6.9-2



$$\frac{1}{2} \div \frac{1}{3} = ?$$

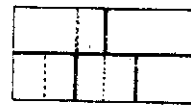

$$\frac{1}{2} \div \frac{1}{3} = 1\frac{1}{2}$$

Fig. 6.9-3

$$\frac{1}{3} \div \frac{1}{2} = \frac{2}{3}$$

Take the strip showing quarters and below it keep the strip showing thirds in proper alignment.

Observe that there are  $1 \frac{1}{8}$  or  $9/8$  *two thirds* in a  $3/4$ , read and record.

$$\frac{3}{4} \div \frac{2}{3} = \frac{9}{8} \text{ or } 1 \frac{1}{8} \quad \text{Fig. 6.9-4}$$

The excess portion beyond  $2/3$  in  $3/4$  is  $1/8$  of  $2/3$  found by folding or looking for strip with proper subdivisions. (Observe that 1 represents here  $2/3$  and the eighth  $1/8$  of  $2/3$ )

Observe also that *two thirds* is  $8/9$  of *three fourths*, read and record.

$$\frac{2}{3} \div \frac{3}{4} = \frac{8}{9}$$

Take five collections of 12 objects each. Consider the collection as a whole and divide one of them into groups of 6, then another into groups of 4, then another into groups of 3, then another into groups of 2 and then the last into groups of 1 with fractions specified in each grouping. Fig. 6.9-5

Observe that  $1 \div \frac{1}{2} = 2$  ( $12 \div 6 = 2$ ) and

Observe that  $\frac{1}{2} \div \frac{1}{3} = \frac{3}{2}$  or  $1 \frac{1}{2}$  ( $6 \div 4 = 1 \frac{1}{2}$ )

and  $\frac{1}{3} \div \frac{1}{2} = \frac{2}{3}$  ( $4 \div 6 = \frac{2}{3}$ )

Observe that  $\frac{3}{4} \div \frac{2}{3} = \frac{9}{8}$  or  $1 \frac{1}{8}$  ( $9 \div 8 = 1 \frac{1}{8}$ )

and  $\frac{2}{3} \div \frac{3}{4} = \frac{8}{9}$  ( $8 \div 9 = \frac{8}{9}$ )

Observe that the division can be done by multiplying the fraction to be divided by the reciprocal of the dividing fraction.

## 6.10

### A. Simple fractions in decimal notation

- B. A fraction having in its denominator any higher unit of the place value denary system (10, 100, 1000 etc.) is a decimal fraction and is written with the denominator omitted and prefixing the numerals with a decimal point if the fraction is proper. If it is an improper





$$\frac{3}{4} \div \frac{2}{3} = ?$$

$$\frac{3}{4} \times \frac{3}{2} = \frac{9}{8}$$

$$\frac{2}{3} \div \frac{3}{4} = ?$$

$$\frac{2}{3} \times \frac{4}{3} = \frac{8}{9}$$

Fig. 6.9-4

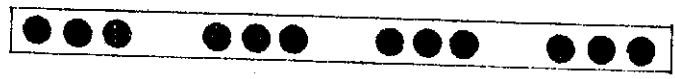

$$1 \div \frac{1}{2} = 2$$

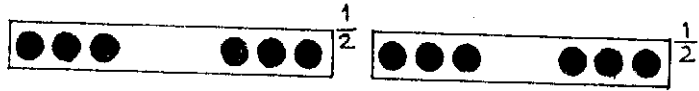

$$1 \div \frac{1}{3} = 3$$

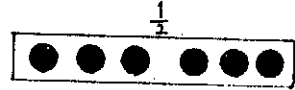
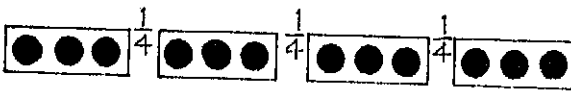

$$\frac{1}{2} \div \frac{1}{3} = \frac{6}{4} \text{ or } \frac{3}{2}$$



$$\frac{3}{4} \div \frac{2}{3} = 1\frac{1}{8} \text{ or } \frac{9}{8}$$



$$\frac{2}{3} \div \frac{3}{4} = \frac{8}{9}$$

Fig. 6.9-5

fraction, the decimal point is fixed after the number of higher units contained in the numerator.

A simple fraction when written into an equivalent fraction with a suitable higher unit in the denominator can be expressed as a decimal fraction.

A decimal fraction can be written into a simple fraction by removal of the decimal point and restoring the appropriate higher units in the denominator and expressing if need be in its simplest equivalent form. Every whole number can be treated as a decimal fraction.

C. Abacus, metre scale,  $10 \times 10$  square ruled sheet, ten-square strips, loose squares.

D. Take a five spike abacus. The place values of spikes from the right are 1, 10, 100, 1000 etc. Observe the successive values are got by multiplying each value by 10, proceeding from right to left.

Proceeding from left to right, observe that from a place value, the place values to the right are got successively by taking  $1/10$  of each value. *This is extended beyond units place to more places with values and so on.*

Thus the *extended abacus* can be used to introduce and represent decimal fractions. *Fig. 6.10-1*

Not only that, any spike can be taken to represent a whole or unit and the spikes to the right to represent fractions of the whole or unit with the place values

$$\frac{1}{10}, \frac{1}{100}, \frac{1}{1000}$$

of the whole. To the left the place values become 10, 100, 1000 etc. times the whole or the unit

From the abacus observe that

$$\frac{1}{10} = .1, \quad \frac{1}{100} = .01 \left( = \frac{0}{10} + \frac{1}{100} \right)$$

$$\frac{1}{1000} = .001 \left( = \frac{0}{10} + \frac{0}{100} + \frac{1}{1000} \right)$$

Take a ten strip square, consider it a whole. Now each division gives a tenth of the whole. Take more strips of the same size and width, one marked in halves and the other in fifths. Keep the strips one below the other and observe that

$$\frac{1}{2} = \frac{5}{10} = .5$$

$$\frac{1}{5} = \frac{2}{10} = .2$$

*Fig. 6.10-2*

Take a ten by ten square sheet consider it a whole. Now each small square gives a *hundredth* ( $\frac{1}{100}$ ) of the whole. From the square

## EXTENSION OF PLACE VALUES TO THE RIGHT ON AN ABACUS

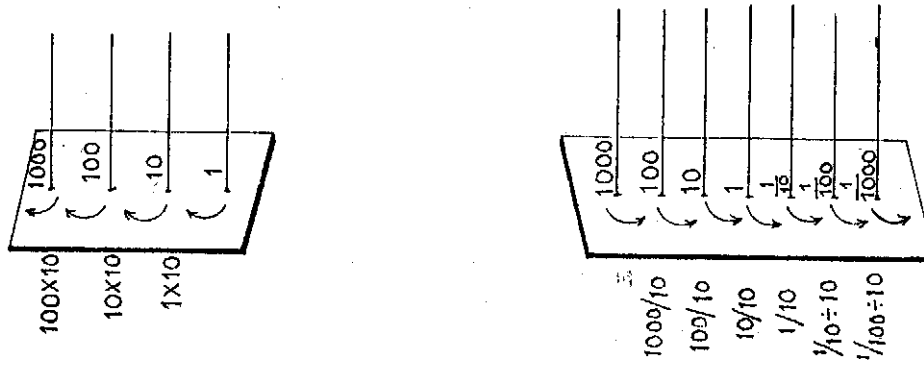

Fig. 6.10-1

## SIMPLE FRACTIONS IN DECIMAL FORM

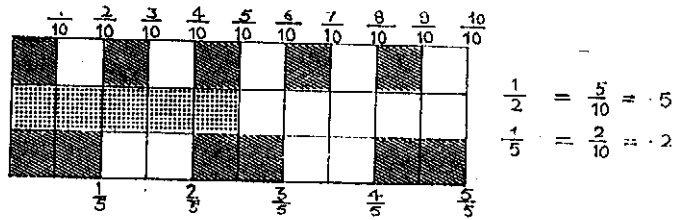

Fig. 6.10-2

observe that

$\frac{1}{2}$  of the sheet is 50 squares. So

$$\frac{1}{2} = \frac{50}{100} = .50 \text{ or } .5 \text{ (.1 repeated 5 times)}$$

$\frac{1}{4}$  of the sheet is 25 squares

$$\frac{1}{4} = \frac{25}{100} = .25 \text{ (10 repeated 25 times) and so on.}$$

*Fig. 6.10-3*

Take the *metre scale*. Consider metre as a unit, then each decimetre is  $\frac{1}{10}$  or .1 of metre; each cm is  $\frac{1}{100}$  or .01 of metre and each millimetre is  $\frac{1}{1000}$  or .001 of metre.

## 6.11

### A. Addition and subtraction of demical fractions.

B. Since decimal fractoins have digits with place values, they can be added place wise as the way the whole numbers are added once the places are properly aligned.

Two pure decimal fractions can be compared by comparing step by step digits in places from the right, unlike comparing step by step from the left in the case of whole numbers.

Two mixed decimal fractions can be compared by comparing the whole parts alone. Doing subtraction of a decimal fraction from a greater decimal fraction is *as in* subtracting a whole number from a greater whole number, once the decimal fractions are represented in proper alignment.

C. Five spike abacus, beads, ten square column paper abacus.

D. For addition of two decimal fractions, represent them on the abacus, after fixing the units spike and allocating the spikes to the right for places in decimal fractions and do addition as in doing addition of whole numbers. *Fig. 6.11-1*

For subtraction of a decimal fraciton from a greater decimal fraction, represent the greater decimal fraciton on the abacus, make adjustments to have enough beads in the spikes to remove beads from places in the subtrahend decimal fraction, remove and find the difference represented on the abacus after removal.

*Fig. 6.11-2*

## 6.12

### A. Multiplication of decimal fractions—meaning and method

B. Any decimal fraction can be multiplied by a suitable small higher unit (power of 10) to get a whole number. *The number of zeros in the higher unit is the same as the number of places in the fractional part of the decimal.*



The product of two decimal fractions can be done on the same lines as finding the product of two whole numbers by treating the decimal fractions as numbers without decimal point and putting in the product decimal point after as many places from the right as there are in the decimal fractions together.

- C.  $10 \times 10$  square sheet (square ruled);  $10 \times 20$  square sheet (square ruled);  $20 \times 20$  square sheet (square ruled).  
 D. Take the  $10 \times 10$  square sheet. Treat it as a whole. Take  $1/10$  of the square-ruled sheet; a strip is got. Find  $1/10$  of this strip. Observe that one small square is got and since it is  $1/100$  of the square sheet, read and record:

$$\frac{1}{10} \times \frac{1}{10} = \frac{1}{100} \text{ or } .1 \times .1 = .01 \quad \text{Fig. 6.12-1}$$

Take  $2/10$  of the square ruled sheet. A strip is got. Find  $3/10$  of this strip. Observe that 6 small squares are got and since each small square is  $1/100$  of the square sheet, read and record

$$\frac{3}{10} \times \frac{2}{10} = \frac{6}{100} \text{ or } .3 \times .2 = .06 \quad \text{Fig. 6.12-2}$$

Take  $10 \times 20$  square sheet; consider  $10 \times 10$  square portion in it as a whole.

Observe from the sheet that

$$1.2 \times .3 = .36$$

$$.12 \times 3 = .36$$

$$12 \times .03 = .36, \text{ and so on.} \quad \text{Fig. 6.12-3} \quad \text{Fig. 6.12-4}$$

Take  $20 \times 20$  square sheet. Consider  $10 \times 10$  square portion in it as a whole.

Observe

$$1.2 \times 1.3 = 1.56$$

$$.12 \times 13 = 1.56$$

$$12 \times .13 = 1.56 \text{ an so on.} \quad \text{Fig. 6.12-5}$$

Observe that these multiplications of two decimal fractions can be done by doing multiplications of corresponding whole numbers got by removal of decimal point in each and fixing the decimal point in the product from the right after counting as many places as there are together in the fractional parts of the decimal fractions. Take the abacus with spikes fixed to represent place  $1/10$ ,  $1/100$ ,  $1/1000$  etc. Observe that removal of a bead from a spike to the place immediately to its right spike reduces the value of the bead to its tenth.

$$1000 \text{ reduced to } 100 \left( \frac{1}{10} \times 1000 \right)$$

$$100 \text{ reduced to } 10 \left( \frac{1}{10} \times 100 \right)$$

# SIMPLE FRACTIONS IN DECIMAL FORM

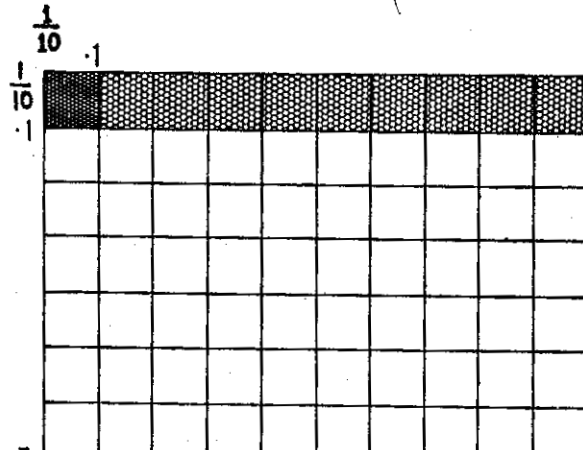

Fig. 6.12-1

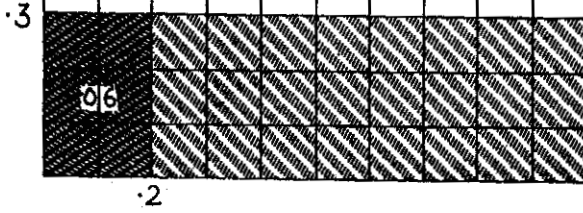

Fig. 6.12-2

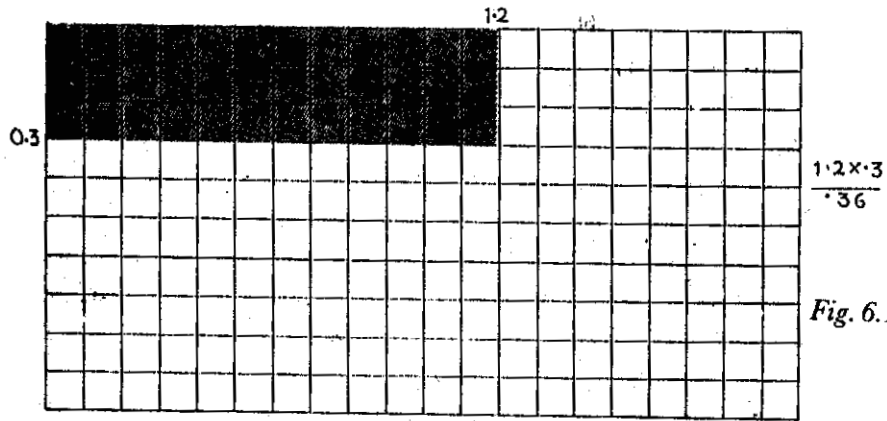

Fig. 6.12-3

Multiplication of decimal fractions

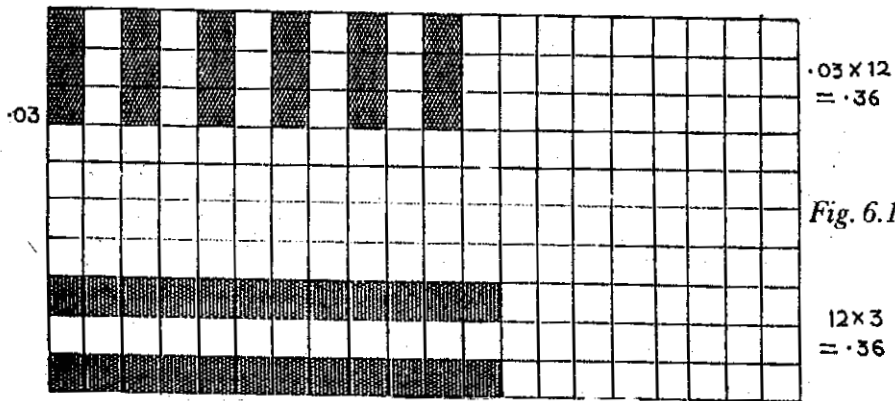

Fig. 6.12-4

$$12 \times 3 = 36$$

10 reduced to  $(\frac{1}{10} \times 10)$

1 reduced to  $\frac{1}{10}(\frac{1}{10} \times 1)$

$\frac{1}{10}$  reduced to  $\frac{1}{100}(\frac{1}{10} \times \frac{1}{10})$  · *Fig. 6.12-6*

Observe also that removal of a bead from a spike to the place after next in the right side reduces the value of the bead to its 1/100 and so on.

1000 reduced to 10  $(\frac{1}{100} \times 1000)$

100 reduced to 1  $(\frac{1}{100} \times 100)$  · *Fig. 6.12-7*

10 reduced to  $\frac{1}{10}(\frac{1}{100} \times 10)$

and so on.

To multiply a decimal fraction by .1, represent the decimal fraction on the extended abacus and transfer the beads in each spike to the spike immediately to the right, starting from the right end and read the fraction represented and that gives the product of the decimal fraction taken when multiplied by .1. *Fig. 6.12-8 Fig. 6.12-9*  
To multiply a decimal fraction by .01, proceed as before remembering that transferring of beads now should be to the 3rd spike to the right.  
To multiply a decimal fraction by .2, show multiplication by .1 on the spike and then double the number of beads in each spike and read and record what is represented finally and so on. *Fig. 6.12-10*

- E. With their growing experience in fixing the decimal point in the product of two decimal fractions by counting the total number of places after the decimal point in the product, the pattern becomes meaningful and the take off stage can be assumed to have been reached.

## 6.13

### A. Division with decimal fractions—meaning and method

B . Division of a decimal fraction by another can be done by multiplying both of them by the smaller higher unit needed to make it a division in whole numbers. Division of a decimal fraction by a smaller whole number is similar to dividing a whole number by another smaller whole number, once care is shown in fixing the decimal part of the quotient.

A smaller whole number can be divided by a greater whole number if the whole numbers are treated as decimal fractions; the division is similar to division of a whole number by a smaller whole number, keeping in view the place values extended to the right.

Division of a decimal fraction by another can be done by multiplying



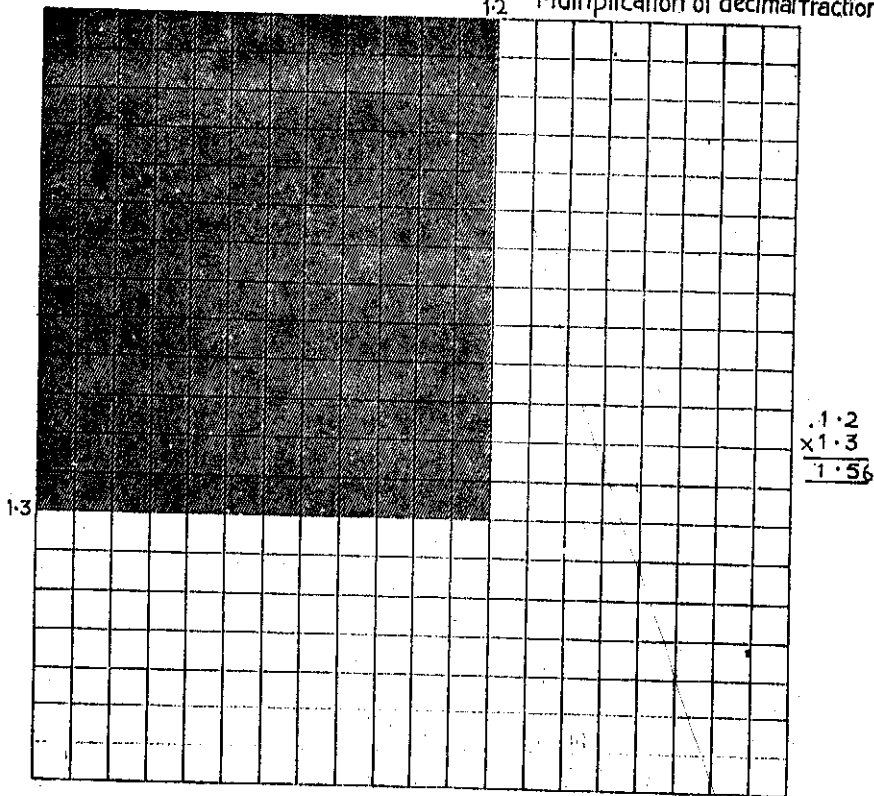

Fig. 6.12-5

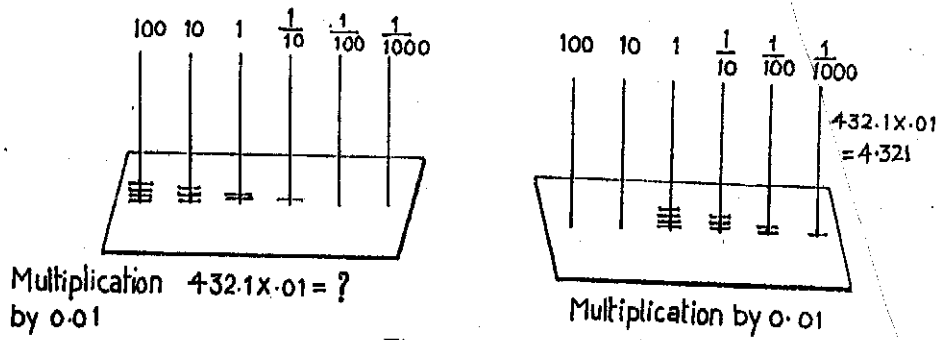

Fig. 6.12-6

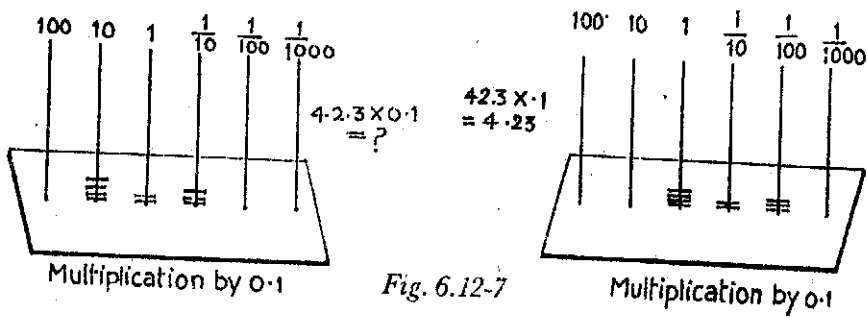
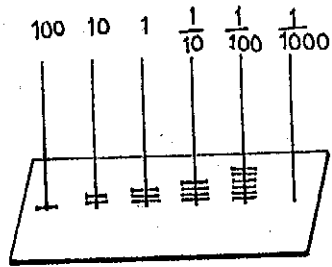
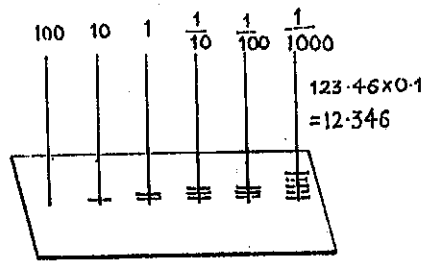

Fig. 6.12-7



Multiplication by 0.1  
 $123.46 \times 0.1 = ?$



Multiplication by 0.1  
 $123.46 \times 0.1 = 12.346$

Fig. 6.12-8

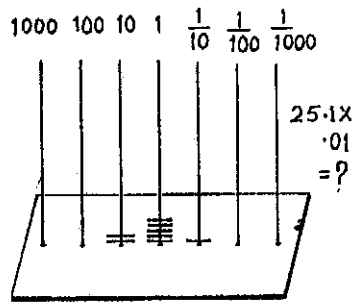

Multiplication by 0.01  
 $25.1 \times 0.01 = ?$

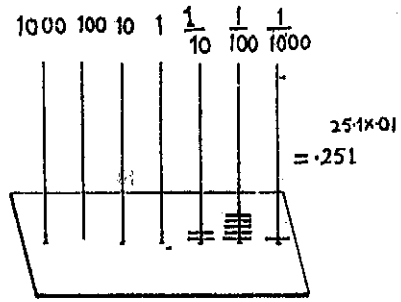

Multiplication by 0.01  
 $25.1 \times 0.01 = 0.251$

Fig. 6.12-9

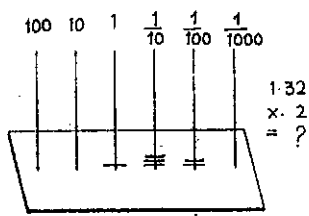

Multiplication by 0.2

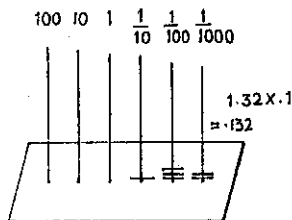

Multiplication by 0.2  
 is multiplication by 0.1  
 and then by 2

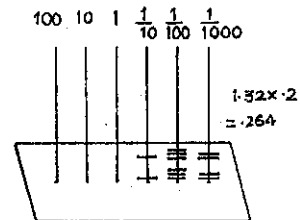

Multiplication by 0.2

Fig. 6.12-10

both of them by the higher unit which would make the one with more places in the fractional part among the two, a whole number. The division then becomes a whole number divided by a whole number.

- C.  $10 \times 10$  square sheet (ruled)  
 $10 \times 20$  square sheet (ruled)  
 $20 \times 20$  square sheet (ruled)
- D. Take the  $10 \times 10$  square sheet. Mark out .4 that is 4 ten square strips. Divide 4 ten square strips into 2 equal parts. Observe that each part is .2 and record  
 Find how many .2's are there in .4? Observe that there are two .2's in .4 and record

$$.4 \div .2 = \text{or } \frac{4}{2} = 2$$

Observe that this is the same as  $4/2$ .

Divide .4 by .04. Observe that there are ten .04s in .4 and

$$\frac{.4}{.04} = 10 \quad \text{Fig. 6.13-1}$$

Observe that this is the same as  $4/.4$  and  $40/4$  and so on.

Take  $10 \times 20$  square sheet.

$$\frac{1.6}{.2} = 8 \quad \text{also } \frac{16}{2} = 8, \quad \frac{.16}{.2} = .8, \quad \frac{.16}{.2} = .08 \quad \text{Fig. 6.13-2}$$

and so on.

- E. With this experience, division process with decimal fractions becomes meaningful and the take off stage can be assumed to have been reached.

Take  $20 \times 20$  square sheet.

Observe that

$$\frac{2.4}{1.2} = 2, \quad \text{also } \frac{24}{12} = 2, \quad \frac{.24}{.12} = 2.$$

$$\frac{.24}{12} = .02 \quad \frac{.8}{.04} = 20 \quad \text{also } \frac{8}{.4} = 20$$

and also

$$\frac{80}{4} = 20$$

6.14

## A. Fractions and Percentages

- B. A simple fraction having 100 in its denominator is a percentage. Two fractions can be compared by comparing their numerators, when the two fractions have the same denominator. So two percentages can be compared easily. Of two percentages, the one with greater number is greater.

DIVISION OF DECIMAL FRACTIONS  
ON A SQUARE RULED SHEET

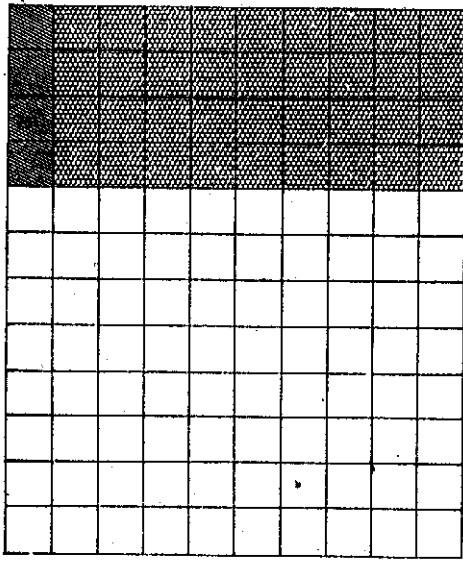

$$\frac{4}{0.4} = 10$$

*Fig. 6.13-1*

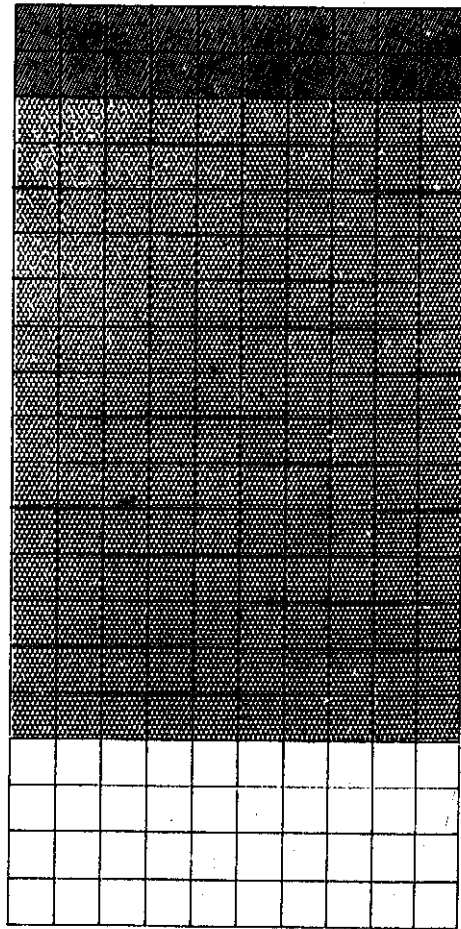

$$\frac{1.6}{0.2} = 8$$

*Fig. 6.13-2*

A decimal fraction having two decimal places only after the decimal point is a simple percentage.

To convert a simple fraction into a percentage, multiply by 100% or shift the decimal point 2 places to the right and affix the symbol %.

To convert a percentage into a simple fraction, take the figure of the percentage in the numerator and 100 in the denominator.

To convert a percentage into a decimal fraction, fix the decimal point two places to the left, if the percentage has two figures.

C.  $10 \times 10$  square sheet (square ruled)

$20 \times 20$  square sheet (square ruled)

D. Take  $10 \times 10$  square sheet and treat it as a whole. Observe that  $\frac{1}{2}$  of the square is 50 small squares and so record

$$\frac{1}{2} = \frac{50}{100} = 50\% = .5$$

Observe also that

$$\frac{1}{2} \times 100\% = 50\%$$

Observe that  $\frac{1}{20}$  of the square is 5 small squares and so record

$$\frac{1}{20} = \frac{5}{100} = 5\% = .05 \quad \text{Fig. 6.14-1}$$

Observe that 25% is  $\frac{1}{4}$  of the square and so record

$$25\% = \frac{25}{100} = \frac{1}{4} \text{ and } 25\% = 0.25$$

and so on:

$$\frac{5}{100} = \frac{1}{20}$$

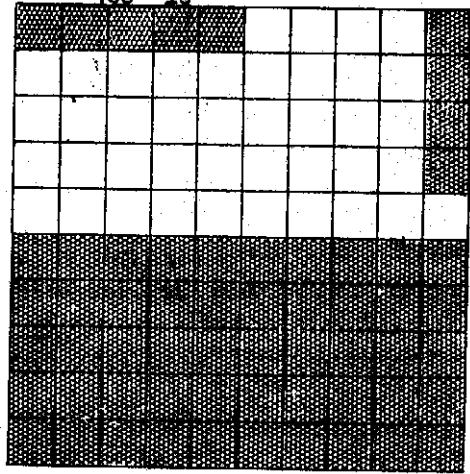

$$\frac{4}{100} = \frac{1}{25}$$

$$\frac{50}{100} = \frac{1}{2}$$

*Fig. 6.14-1*

## UNIT VII

### Concepts through Practical Work for Applicability

- 7.1 Ratio and fractions
- 7.2 Direct variation.
- 7.3 Inverse variation
- 7.4 Averages
- 7.5 Data in pictures

#### 7.1

##### A. Ratio and fractions

**B.** Two sets of objects can be compared and the comparison expressed as a ratio or a fraction. Two quantities can be compared and the comparison expressed as a ratio or a fraction when they are measured in terms of the same units. When the terms of a ratio are multiplied by the same number or divided by the same number, the value of the ratio is not changed; in other words *equivalent ratio is obtained*.

**C.** Seeds, black beans and white beans, mixtures, cups, national flag and photographic sizes. *Fig. 7.1-1*

**D.** Take two collections consisting of seeds 3 and 5. Observe that their ratio is 3:5 if a 3 seed collection is compared with a 5 seed collection or 5:3 if a 5 seed collection is compared with a 3 seed collection. A 3 seed collection is  $\frac{3}{5}$  of 5 seed collection and a 5 seed collection is  $\frac{5}{3}$  of a 3 seed collection.

Combining a 3 seed collection and a 5 seed collection to make a bigger collection, observe that 3 seed collection is  $\frac{3}{8}$  of the bigger collection and the 5 seed collection is  $\frac{5}{8}$  of the bigger collection.

2 cups of ground nut flour are mixed with 3 cups of sugar. Make another mixture with 2 cups of ground nut flour and 5 cups of sugar. Observe and verify by tasting that the first mixture is blander than the second mixture.

$$\left(\because \frac{2}{3} > \frac{2}{5}\right)$$

It can also be observed that the second mixture is sweeter than the first mixture.

$$\left(\because \frac{2}{3} > \frac{2}{5}\right)$$

CONCEPT OF RATIO

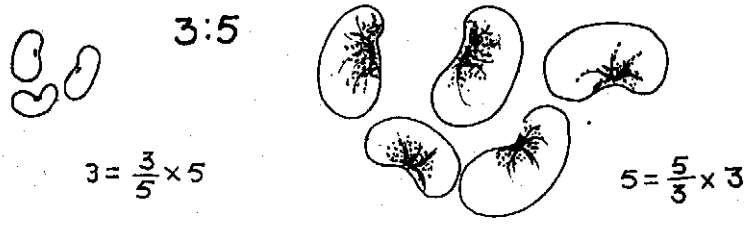

*Fig. 7.1-1*



$$\left( \begin{array}{c} 5 \\ \longrightarrow \\ 3 \end{array} \right)$$

Make packets, each having 5 black beans and 3 white beans. Take four such packets and observe that there are 20 black beans and 12 white beans. Observe that the ratio of black beans to white beans remains the same.

$$5:3 = 20:12 = 5 \times 4 : 3 \times 4 \quad \text{Fig. 7.1-2}$$

Observe also that 10 black beans and 6 white beans are in the same ratio.

$$20 : 12 = 10 : 6 = 20 \div 2 : 12 \div 2$$

Take samples of our national flag and measure the length and the width of each of the national flags. What is their ratio? Observe that in one sample of the national flag the length is 6 cm and width 4 cm. So the length and width are in the ratio of 6 : 4. In the second sample of the national flag of another size, the length is 30 cm and width 20 cm. Here the length and width are in the ratio of 30 : 20. Observe that 30 : 20 and 6 : 4 are equivalent; in other words they represent the same ratio. The larger flag is only an (proportionate) enlargement of the smaller flag. It can also be said the small flag is only a (proportionate) reduction of the larger. Measure the photographic sizes, cabinet, postcard, passport and stamp and observe that the ratio of the length and width of each size remains the same.

Fig. 7.1-3

7.2

### A. Direct variation

- B. If two quantities take values such that the values bear a constant ratio, then one quantity varies directly as the other quantity.
- C. Square-ruled sheets, button cards (tailors' waste), notebooks of the same make and size, sheets, punching pliers.
- D. Cut out squares, larger and smaller, from a square ruled sheet. Make out a table giving in two columns the edge and the perimeter of each square. Observe that the ratio of the edges of two squares is the same as the ratios of the perimeters of the two squares and vice versa. In other words, observe that *the perimeter of a square varies directly as its edge.*

collect button cards of the same kind (preferably from tailor's waste). Draw up a table giving in two columns the number of cards and the number of buttons carried by them. Observe that the number of buttons varies directly as the number of cards and vice versa.

Collect notebooks (of the same make and size). Draw up a table giving in two columns the number of sheets and the number of

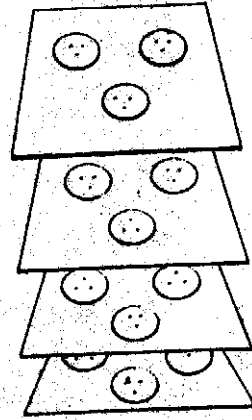
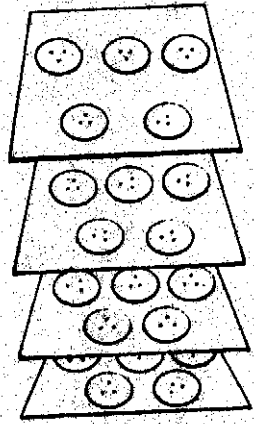

$$5:3 = 20:12 = 5 \times 4 : 3 \times 4$$

$$20:12 = \frac{20}{4} : \frac{12}{4} = 5:3$$

Fig. 7.1-2



National flags of different sizes have the same ratio of length and breadth

Fig. 7.1-3

notebooks. Observe that the number of sheets varies directly as the number of notebooks.

Collect twice folded sheets and punch them a number of times. Draw up a table giving in two columns the number of punch holes and the number of sheets used. Observe that the number of punch holes varies *directly* as the number of sheets used and vice versa.

7.3

#### A. Inverse variation

B. If two quantities take values such that the product of a pair of values of the two quantities is constant or the ratio of two values of one quantity is equal to the ratio of inverses of the two values of the other quantity, then one quantity varies inversely as the other.

C. Seeds and paper packets or plastic bags; square ruled sheet; square slips (of the same size); paper strips (printers' waste).

D. Take a collection of seeds and paper packets. Note down in how many ways the collection can be equally distributed; in other words, the divisors of the number of seeds in the collection. At the rate of seeds equal to each divisor per packet, put the seeds in packets. Draw up a table giving in two columns the number of seeds in each packet and the number of packets used. Observe that the number of packets varies *inversely* as the number of seeds packed in each and vice versa.

Cut out rectangles from a square-ruled sheet such that the rectangles have the same area. Draw a table in two columns giving the length and the width measurements. Observe that the measure of length varies *inversely* as the measure of width and vice versa.

Take strips of paper of the same length. Fold each into equal parts in different ways. Draw up a table in two columns giving width of each folded portion (as a fraction of length of the strip or in cm measure) and the number of foldings made. Observe that the number of foldings varies *inversely* as the width of each folded portion and vice versa.

7.4

#### A. Average (Arithmetic mean)

B. The mean of a collection of values lies between the greatest value and the smallest value in the collection. When different values are equalised, each of the equal values becomes the mean of the different values. Comparison of two groups in respect of some measurable characteristic is done through average scores of the groups. If two groups have the same number of measures, then comparison can be done with the totals themselves.

- C.** Beans, sticks of different lengths.
- D.** Collect two groups of children *equal* in number. Spill beans. Fix an interval of time. Use stop watch. Ask each group to collect the beans during the interval. Find the total number of beans picked up by each group. The group which has picked up more is more efficient.

Collect two groups of students *unequal* in number. Fix an interval of time. Spill beans. Use stop watch. Ask each group to collect the beans during the interval. Find the total number of beans picked up by each group. Assume that each group consists of equally efficient pickers and find what each one should have picked up, the number giving the mean for the group. Find the mean for the other group. Observe that the group with greater mean score is more efficient. Observe also that the mean score for each group is between the lowest score and the highest score in each group.

Take two sticks of different lengths. Devise a strategy such that they are of equal length, without altering their total length. The strategy is to find the difference in length and cut off from the longer stick from one end a bit equal to half of the difference of their lengths and attach the bit to the shorter stick. Observe that the mean length lies between their original lengths.

*Fig. 7.4-1*

Take a bunch of sticks (having more than two) and find a strategy by means of which they can all be made of equal length, without their total length being changed. Find the mean length and suggest the adjustment by way of elongation or reduction for each stick. Again observe that the mean length is more than the shortest one and less than the longest one. Observe also that the stick of mean length may or may not be found among the sticks in the bunch.

7.5

**A. Data in pictures (pictograms)**

- B.** Numerical information can be displayed or stored in pictograms for ready reference.
- C.** Match boxes (of the same make and size), cubes (of the same size) and used stamps (of the same kind or size).
- D.** Place on the table as many match boxes as there are children in the class. Each child picks up a match box. Make 12 labels for the months of a year. Fix the labels on the table in a row. Ask children to come, one by one, and place their match boxes respectively on the months of their birth. Observe that these piles of boxes store information about the number of children (of the class) born in each month. Fix on a sheet of paper used stamps for the same purpose.

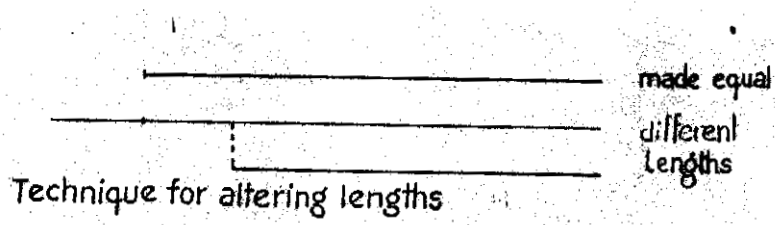

Technique for altering lengths

*Fig. 7.4-1*

Collect information from the class regarding the modes of transport resorted to by children to school from their homes. Draw up a table giving information in two columns the modes of transport and the number of children taking to each mode of transport. Present this information using labels for modes of transport and cubes for the number of boys. Fix on a sheet of paper used stamps for the same purpose.

Collect information from the class regarding the number of siblings (brothers and/or sisters) each child has. Draw up a table giving information in two columns the number of siblings and the number of children having the number of siblings. For each number of siblings starting from 0 to 10, pile up as many match boxes or cubes one over the other, as the number of children. Fix on a sheet of paper used stamps for the same purpose.

## UNIT VIII

### Shapes and Number

- 8.1 Classifying and naming solid shapes
- 8.2 Testing straightness and flatness
- 8.3 Looking at solid shapes
- 8.4 Making hollow solid shapes
- 8.5 Plane shapes—rectilinear
- 8.6 Plane shapes—circular
- 8.7 Angles and their kinds and measures
- 8.8 Angles in plane shapes and angle sums of plane shapes
- 8.9 Symmetry in plane shapes

8.1

#### A. Classifying and naming solid shapes

**B.** Cubes, cuboids, prisms and pyramids are solids with flat faces; cylinders and cones have curved and flat surfaces.

**Spheres have only curved surfaces. Prisms and cylinders have top and bottom faces of the same shape and size. Pyramids and cones have no top surface but only bottom and side surfaces.**

**C.** Pairs of geometric solids (in wood or plastic) of different sizes. Moulds to make solids of different sizes, plasticine and clay.

**D.** Classification of solids according to characteristics is a valuable experience. **Fig. 8.1-1**

Touch, feel and see the difference between a curved surface and a flat surface.

Classify the set of geometric solids into those having (1) flat surfaces only (cubes, cuboids, prisms and pyramids) (2) curved surfaces only (spheres) (3) flat and curved surfaces (cylinders and cones)

Classify the solids into those having side faces (1) four edged (prisms, cubes and cuboids) and (2) three edged (pyramids). Classify the solids having (1) top and bottom faces flat (prisms, cubes, cuboids, cylinders) and (2) bottom face alone flat and top a corner (pyramids and cones). **Fig. 8.1-2**

Pick out solids with all faces four edged (cubes, cuboids).

Pick out solids each of which has all faces identical and name them.

Trace one face and check whether the other faces fit over the trace. (cubes)

Pick out solids each of which has opposite faces identical and name them. Trace one face and check whether the opposite face fits over the trace. Check similarly the other two faces of opposite faces. (cuboids)

SOLIDS

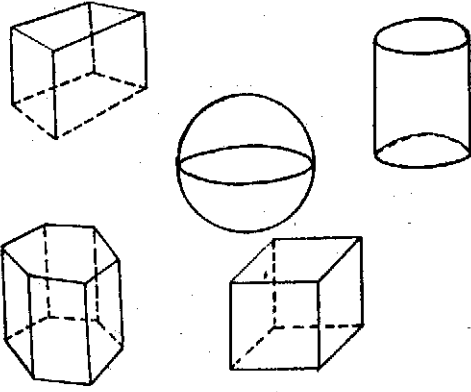

Fig. 8.1-1



SOLIDS

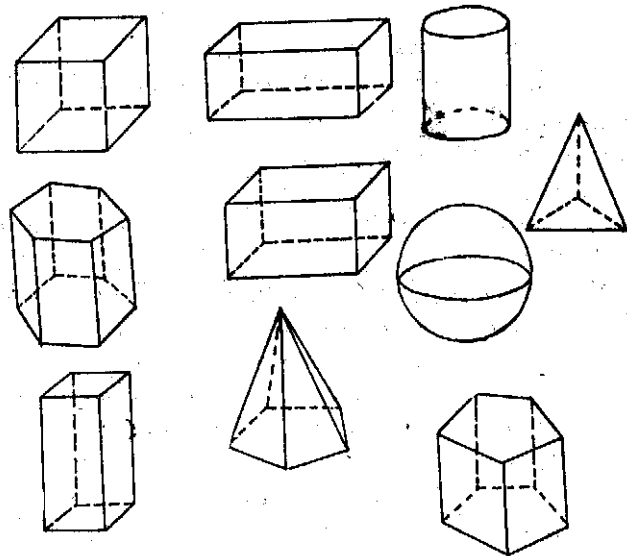

Fig. 8.1-2



Pick out solids with side flat faces alone four edged and name them (prisms)

Pick out solids each of which has only one flat circular face and name them (cones)

Pick out solids each of which has two flat circular faces and name them (cylinders)

Pick out solids each of which has zero flat faces and name them (spheres)

Use moulds to make clay or plasticine models of solids.

- E.** It is neither possible nor desirable to develop precise ideas about solids from the very start and exhaust all kinds of solids. Precision and coverage of kinds develop gradually with growth in perception and understanding. Vagueness is bound to create some confusion but confusion should be kept within limits so that it gets cleared up gradually and is made to vanish ultimately.

Naming the shapes of solids in the environment is a reinforcement exercise in learning.

bricks (cuboidal), cartons (cuboidal), tins (cylindrical), sharpened portion of a pencil (conical), dice (cubical), ice-cubes (cubical), balls (spherical), tents (conical or pyramidal)

## 8.2

### A. Testing straightness and flatness

- B.** An edge of a ruler is straight if no gap is formed when a line is drawn along the edge with the ruler kept in one position and again when a line is drawn over the line drawn already, along the same edge with the ruler kept in the reverse position. A surface is flat when a straight edge leaves no gap when it is moved all over the surface.

- C.** A stiff card board strip with one (long) edge straight and the other (long) edge slightly curved.  
Paper.

A wooden plank with the top face slightly curved and bottom face flat.

- D.** Fix a paper (on the flat surface of a table or a desk.) To determine the straight edge of the cardboard strip, press the strip on the paper and draw a line along the edge. Reverse the position of the strip and draw a line to fall over the previous line along the same edge. If no gap is left, the edge is straight; otherwise it is curved. *Fig. 8.2-1*

To determine which surface (bottom or top) of the plank is flat, move the straight edge all over the surface watching for gap below the edge. If no gap is seen, the surface is flat. *Fig. 8.2-2*

- E.** Experience is more important in initial stages than verbalisation. There should, therefore, be enough experience to be gained through experimentation and exploration. Also informal verbalisation should precede formal verbalisation.

# Testing a Straight Edge

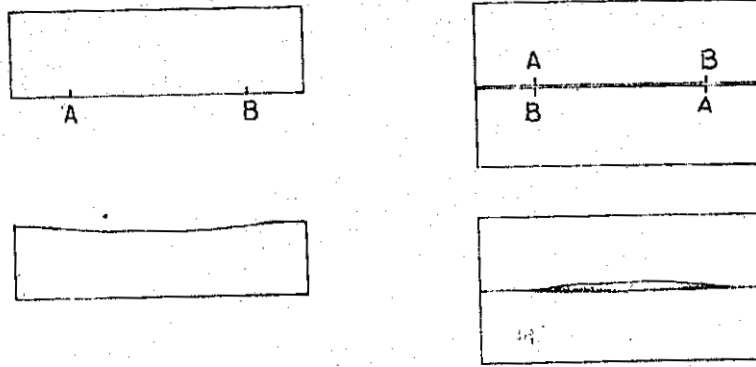

Fig. 8.2-1

# Testing flatness

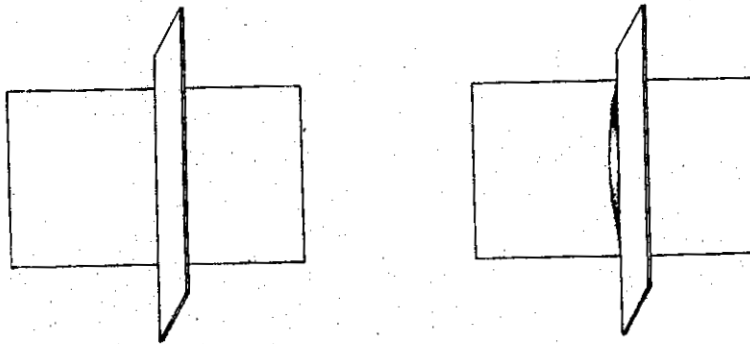

Fig. 8.2-2

### A. Looking at solid shapes

**B.** A cuboid has six flat surfaces, twelve straight edges and eight corners.

A cube has six flat surfaces, twelve straight edges and eight corners.

In a prism (1) the number of straight edges is three times the number of edges of the bottom or top face.

(2) the number of faces is more than the number of edges of the bottom or top face and

(3) the number of corners is twice the number of edges of the bottom or top face.

In a pyramid (1) the number of straight edges is twice the number of edges of the bottom face,

(2) the number of faces is 1 more than the number of edges of the bottom face and

(3) the number of corners is 1 more than the number of edges of the bottom face.

A cylinder has two curved edges and no corners.

A cone has only one curved edge and one corner.

A sphere has no edges and no corners.

When the curved surface of a cylinder is placed on a flat surface, the cylinder lies along a line of the flat surface. When the curved surface of a cone is placed on a flat surface, it also lies along a line of the flat surface. When a sphere is placed on a flat surface, it lies on a point of the flat surface.

Flat surface solids when kept on a flat surface lie over a region.

**C.** A set of geometrical solids in two or three sizes.

**D.** Count the faces, edges and corners of solids and record them and make general observations arising from this study. Chalk the curved surface of a wooden cylinder and place the cylinder gently on a flat surface such that curved surface lies on the flat surface and remove the cylinder. Observe the trace of a line, showing that a cylinder when placed with its curved surface on a flat surface lies along a line. Chalk the curved surface of a wooden cone and do a similar experiment as is done for a cylinder. Observe that the cone also lies along a line on a flat surface.

*Fig. 8.3-1*

Chalk the surface of a wooden sphere and do a similar experiment as is done for the cylinder and the cone. Observe that a sphere lies on a point on a flat surface.

Flat faced solids can be seated with any flat face, showing that a flat faced solid lies over a region of the flat surface.

**E.** Note that flatness is not to be confused with horizontal or vertical surfaces, though the horizontal and vertical surfaces are flat. Also, straightness does not mean horizontal or vertical, though horizontal and vertical lines are straight.

Contact of solids with a flat surface

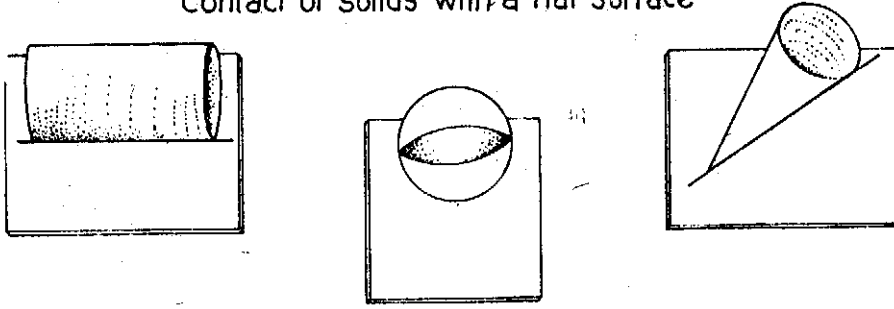

*Fig. 8.3-1*

**A. Making some hollow solid shapes**

**B.** If the long edges (or the short edges) of a (rectangular) paper are brought together, a cylindrical surface is formed. Multifolded paper makes cubes, cuboids and prisms, when opposite edges of the paper are brought together. With a paper sector of a circle, a conical surface is formed.

**C.** Paper rectangles, paper sectors, sticks of the same length.

**D.** Fold a paper such that long edges or short edges are brought together naturally and smoothly and observe the cylindrical surface formed.

Use three papers of the same size. Along the long edges of a base paper keep slanting two other papers such that one edge of each is in line with each long edge of the base so as to get the remaining two edges meet; observe the prism formed.

By bringing the two straight edges of a sector, a conical shape is formed.

Holding four sticks at the four corners of a table slantingly so that the other ends of the sticks meet, observe the pyramids formed.

Fold a paper to have eight equal parts (say). Fold the paper along the creases formed backwards and forwards so that creases offer no resistance when opposite edges of the paper are brought together. By bringing the edges with (1) no parts overlapping (2) two parts overlapping to form one side, (3) four parts overlapping to form two side faces etc. different kinds of prisms can be seen formed. Cubes and cuboids will be special cases of a prism.

**E.** The objective is not to know properties of surfaces but to enjoy the fun of improvisation in making hollow solid surfaces and identifying their shapes.

**A. Plane shapes—rectilinear**

**B.** No (enclosed, rectilinear) shape formed of straight edges can have less than 3 edges.

The faces of a cube are squares

The faces of a cuboid are rectangles

The side faces of a prism are rectangles.

A square has all its edges equal.

A rectangle has opposite edges equal

A triangle has three edges.

A triangle can have two equal edges

A triangle can have all its edges equal

A many-sided figure can have all its edges different or some or all the of the edges equal.

The number of corners of a many sided figure (polygon) is equal to the the number of its edges.

- C. Broom sticks, paper, a (wooden) cube, a (wooden) cuboid.
- D. Trace out the faces of a cube, cut out the traces and observe by overlapping of traces in various ways that the faces of a cube are identical squares.

Trace out the faces of a cuboid, cut out the traces and observe by overlapping of traces that the faces of a cuboid are made up of rectangles in two sizes.

With two sticks, no shape enclosing a space can be built. At least three sticks are needed to build a closed shape. With four sticks, build a shape such that it is like the shape of a paper. *Fig. 8.5-1*

Take two rectangular papers of the same size (tested by overlapping) and (superimpose) place one over the other such that a long edge of one lies along a short edge of the other with the corresponding corners coinciding. The common portion observed is a square. *Fig. 8.5-2*

Take more than four sticks, build many-sided shapes and observe that the number of corners is equal to the number of edges in each case.

## 8.6

### A. Plane shapes—circular

- B. Places (points) at the same distance from one place (point) lie on a circle and the fixed place is the centre of the circle.

A circle has no corners.

A circle has a curved boundary (called the circumference of the circle)

A circle has countless diameters.

Half of the diameter of a circle is the radius of the circle.

A circle has countless radii.

All the diameters of a circle pass through its centre.

A semi circle is bound by half of the circumference and a diameter.

A quadrant of a circle is bound by quarter of the circumference and two radii.

A line across a circle divides it into two unequal parts, the larger part being the major segment and the smaller part the minor segment.

- C. Thread, pencil, paper, bangles of different sizes, tins (cylindrical), compasses, objects, sticks of the same size.
- D. Pick out bangles of equal sizes by placing one over the other. Trace out the bottoms of (cylindrical) tins or trace round bangles on papers and cut out the circular shapes. Observe that there is only one edge in a circular shape and it is curved. Fold a circular paper into halves, open it and fold again into halves in another position. Observe that the two creases (diameters) cut at a point and halved at the point. Fold a circular paper into eighths; the creases (radii) meet at a point (centre) and they are as long as each other. Fold a circular paper into

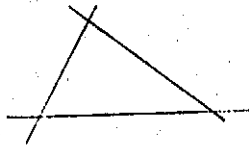

Formation of a triangle

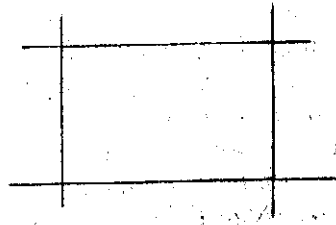
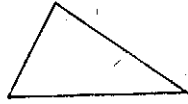

Formation of a rectangle

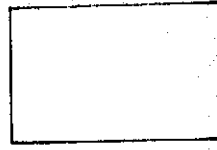

*Fig. 8.5-1*

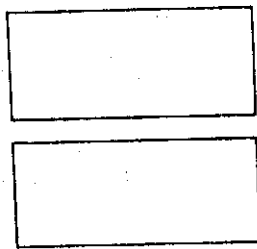

Two strips of the same size

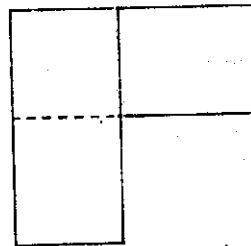

Square by Superimposition of rectangular Strips of the same size

Placement of strips such that one corner and edges along it overlap

*Fig. 8.5-2*

unequal parts. Observe that one part is larger than the other, the larger part being a major segment and the smaller part a minor segment of the circle. Press one end of a thread with your finger and hold a pencil at the other end of the thread and move keeping the thread taut. Observe you can only move round and a circle is drawn. Fix an object. Take sticks of the same size and arrange them such that the one end of each stick is at the object. Observe that the other ends of the sticks lie along a circle.

Fix an object. Take one stick and with that stick to give constant distance from the fixed object, place objects and observe that the objects lie along a circle. *Fig. 8.6-1*

8.7

### A. Angles and their kinds and measures

**B.** When a line is rotated from an initial position, angles are formed with respect to the initial position. When two lines intersect, four angles are formed, two obtuse, opposite and equal and two acute, opposite and equal. Two rays with a common end point form an angle. When two lines intersect such that the four angles are of the same size or measure, each angle is a *right angle*. Obtuse angles are more than a right angle and acute angles are less than a right angle. A right angle is divided into 90 equal angles and each division is a unit angle, a degree in measure. Half of a right angle has 45 degrees. A third of a right angle has 30 degrees. Two thirds of a right angle has 60 degrees. One and one third of a right angle is 120 degrees.

One and two thirds of a right angle is 150 degrees. If two right angles are so placed that their corners coincide and one arm of one lies along one arm of the other the remaining arms of the right angles form a straight line, if they do not coincide.

**C.** Clock face with hands, a pair of dividers, two sticks, papers, waste paper. Take dividers; keeping one arm fixed, rotate the other. Observe the angles being formed by the sweep (from the fixed arm).

**D.** Take a waste paper bit, fold it once and again fold it such that the creases overlap. The angle formed at the corner observed by the sweep from one edge to the other about the corner is a right angle.

*Fig. 8.7-1*

Unfold the bit and observe that four right angles are formed. Take two waste paper bits and make two square corners and place them side by side in such a way that their corners coincide and one edge of one lies along one edge of the other. Observe that the other edges lie along a line and angles formed at the corner are together equal to two right angles.

Take two sticks and place them in such a way that one intersects the other. With a square corner notice that two angles lying opposite



# FORMING RIGHT ANGLES BY PAPER FOLDING

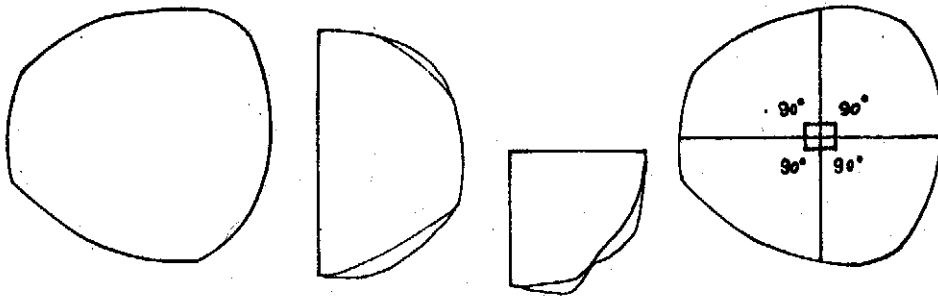
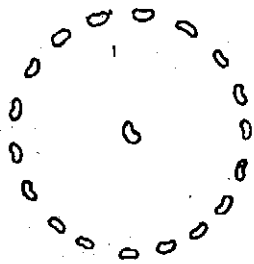
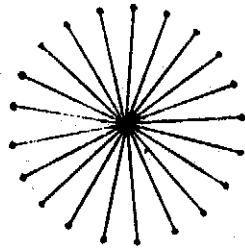

Fig. 8.6-1



Placing objects at the same distance from a fixed object



Placing sticks of the same length with one of their ends meeting at a fixed position.

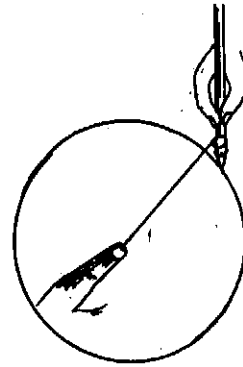

Drawing a circle with a thread and a pencil

Fig. 8.7-1

are less than the square corner and hence *acute* and two other angles also lying opposite are more than a right angle and hence *obtuse*.

Take a sheet of paper, fold it. Open it and fold in another way such that the two creases cross each other. Open the paper and observe the four angles formed. Cut out the angles and by overlapping test, observe that the oppositely lying obtuse angles are equal and the oppositely lying acute angles are equal. *Fig. 8.7-2*

Fold a paper at some point on one of its edges, such that slant foldings from either end overlap to form three equal parts of  $180^\circ$ . The angle formed ultimately by the foldings is  $60^\circ$ . Unfold completely and fold backwards one part. Observe the remaining parts showing  $120^\circ$ . Fold a paper once. Fold again such that the crease overlaps the bottom edge on one side. Unfold and observe that a right angle is divided into two equal parts, each of which is of the measure  $45^\circ$ . Unfold completely and fold backwards one part. Observe the remaining parts showing  $135^\circ$ . *Fig. 8.7-3*

Fold a paper to form  $60^\circ$ . Fold it again to form  $30^\circ$ . Unfold completely and fold backwards one part and observe the remaining parts forming  $150^\circ$ . Use the hands of a clock to rotate and show various angles.

- E. Protractors and set squares can be used to verify the measures of angles got by paper folding.

8.8

### A. Angles in shapes and angle sum of shapes

- B. In a (rectilinear) many edged shape (or polygon), the number of (interior) angles is the same as the number of sides. *The angle sum of a triangle is two right angles.* The angle sum of a four edged (convex) shape (quadilateral) is four right angles. In a triangle all the angles can be equal (equilateral triangle); measure of each angle is then  $60^\circ$ . In a triangle two angles can be equal (isosceles triangle). In A triangle, only one angle can be a right angle or an obtuse angle. All the angles of a square are equal and are each equal to a right angle. All the angles of a rectangle are equal and are each equal to a right angle. The number of non-overlapping triangles into which a polygon can be divided is 2 less than the number of sides of the polygon.

- C. Paper, paper set squares.

- D. Take a rectangular paper. Observe by means of a square corner bit that all the angles of a rectangle are equal and each is equal to a right angle. Make a paper square. Observe by using a square corner bit that all the angles of a square are equal and each angle is a right angle.

Using set squares found in a geometrical instruments box, trace out set squares and cut them out. Combine  $45^\circ$  paper set squares to form shapes and combine  $60^\circ$  set squares to form shapes. Some shapes are

FORMING 60° BY PAPER FOLDING

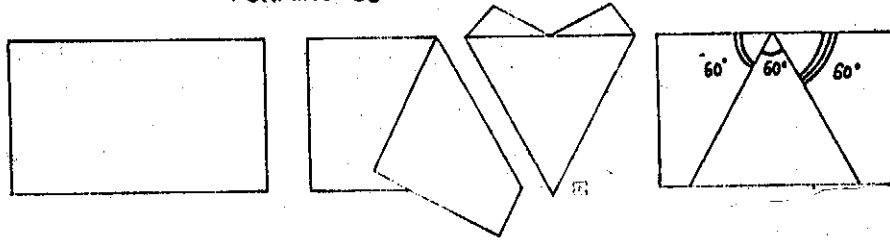

Fig. 8.7-2

FORMING 45° BY PAPER FOLDING

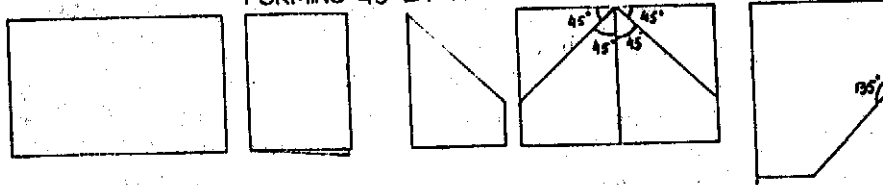

Fig. 8.7-3

triangles and some are four edged shapes. Observe that in the case of triangles, the angle sum is two right angles or  $180^\circ$  and in the case of four edged shapes the angle sum is four right angles or  $360^\circ$ . Cut out paper triangles and cut out three angles in each. Try to arrange the angular regions to lie contiguously such that the triangular corners in them coincide and arms lie along each other, two by two. Observe that the outer-most arms lie along a straight line, showing thereby that the sum of the angles of a triangle is 2 right angles or  $180^\circ$ . Do this exploraiton with more triangles and from the experience obtained, state the property generally. *Fig. 8.8-1*

Alternatively, cut out of paper three identical triangles and place them in such a way that the three angles of any of these triangles are contiguous at a point and observe as before that sum of the angles of a triangle is 2 right angles or  $180^\circ$ .

Cut out of paper four edged shapes (quadilateral). Cut out the four angles and place them contiguously at a point. Do this exploration with more four edged shapes. Observe that the angle sum of a four edged shapes is 4 right angles or  $360^\circ$ . *Fig. 8.8-3*

Cut out of paper a many-edged shape (polygon). Divide it into non over-lapping triangles. Do this exploration with different many-edged shapes. Observe that the number of triangles is 2 less than the number of edges. *Fig. 8.8-4*

No. of edges:	4	5	6	..	
No. of triangle:	2	3	4	..	8.9

### A. Line symmetry in shapes

**B.** A rectangle has two lines of symmetry.

A square has four lines of symmetry.

A triangle having two edges identical (an isosceles triangle) has one line of symmetry. (An equilateral triangle) A triangle having all the three edges equal has three lines of symmetry.

A circle has countless lines of symmetry.

**C.** Paper.

**D.** Take paper rectangles. Fold each into halves and observe that this folding can be done in two ways. The creases seen in the foldings give the lines of symmetry. *Fig. 8.9-1*

Make paper squares. Fold each into halves and obtain that this folding can be done in four ways. The creases seen in the foldings give the four lines of symmetry. *Fig. 8.9-2*

To cut out isosceles triangles out of paper, take a rectangular sheet of paper and fold it as in getting half of the paper. Then fold across two points, one on the crease and the other on the bottom and cut along the slant crease. Unfold and see an isosceles triangle formed. In an isosceles triangle there is only one line of symmetry. *Fig. 8.9-3*

To cut out equilateral triangles out of paper, take a rectangular sheet

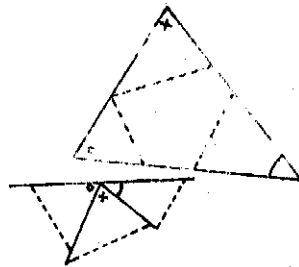
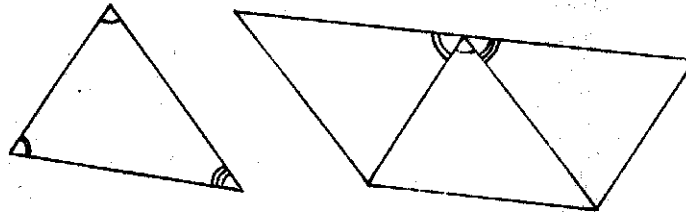

Fig. 8.8-1

BY JUXTAPOSITION OF ANGLES  
CUT OUT FROM A TRIANGLE

SUM OF THE THREE ANGLES OF A TRIANGLE



BY JUXTAPOSITION OF A TRIANGLE  
AND ITS IMAGES

Fig. 8.8-2

Sum of the angles of a quadrilateral

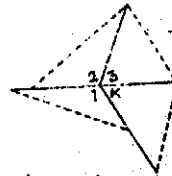
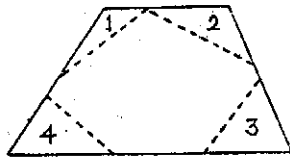

By Juxtaposition of angle cut-out from  
the quadrilateral

Fig. 8.8-3

Quadrilateral

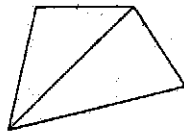

Pentagon

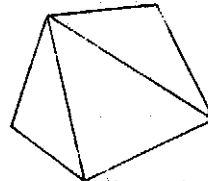

Hexagon

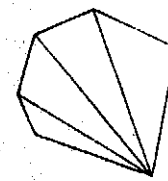

Sum of the angles of a polygon (convex)

Fig. 8.8-4

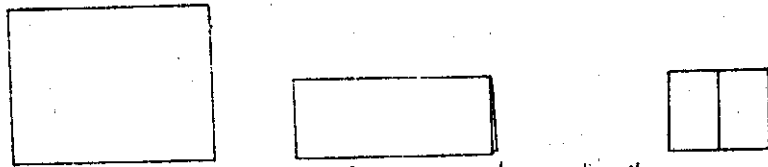

Two Lines of symmetry of a rectangle  
by paper folding

Fig. 8.9-1

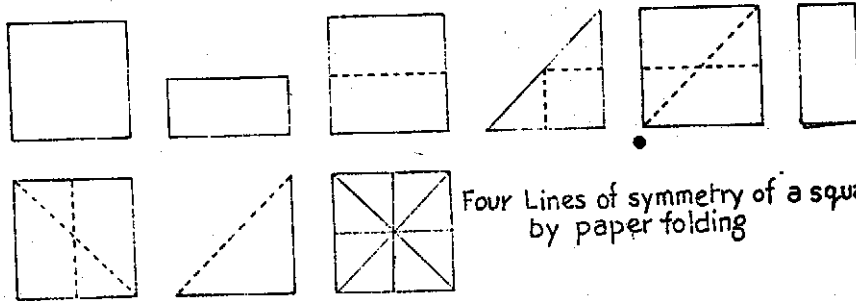

Four Lines of symmetry of a square  
by paper folding

Fig. 8.9-2

An isosceles triangle by paper folding

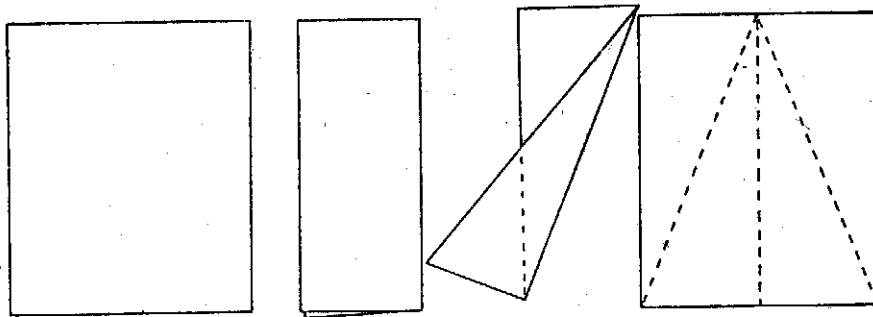

Fig. 8.9-3

of paper and fold it as in getting half of the paper, unfold and fix the central line of symmetry. Now fold so as to bring one corner of the rectangle to lie on creased line and an edge of the rectangle along the corner to pass through the adjoining corner. By folding the folded portion over, it can be observed that the angle formed in one folding is  $30^\circ$ . By folding the other edge of the rectangle about the first chosen corner such that the folding crease runs along the edge of the first fold, observe the triangle formed below and it is an equilateral triangle. Cut out the equilateral triangle. Fold the triangle to halve it. Observe that the folding can be done in 3 ways, showing that an equilateral triangle has three lines of symmetry: *Fig. 8.9-4*  
Cut out paper circle and fold each into halves. Observe that this folding can be done in countless ways, showing that each crease is a line of symmetry.

*Fig. 8.9-5*

An equilateral triangle by paper folding

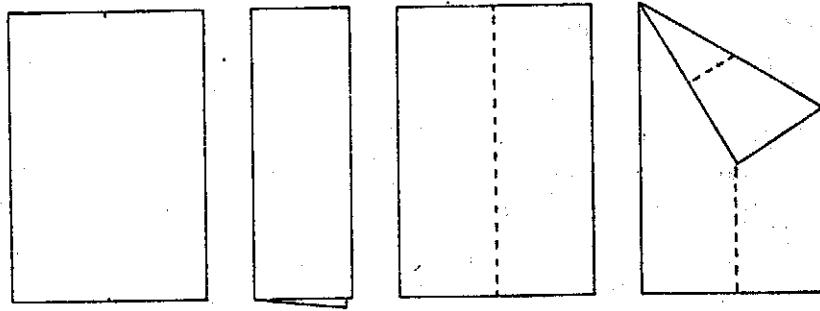

Fig. 8.9-3

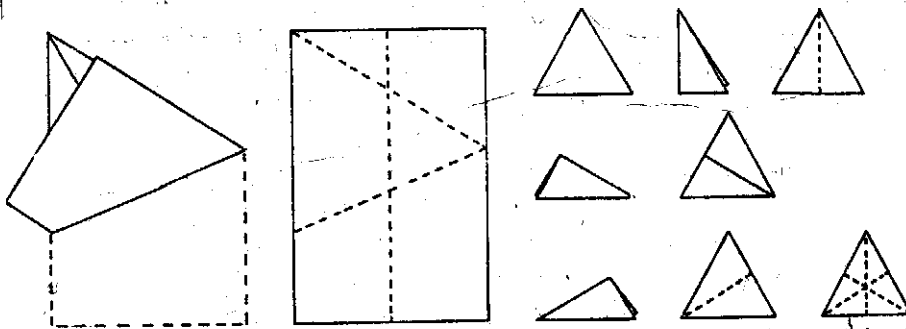

Fig. 8.9-4

lines of symmetry of an equilateral triangle.

Fig. 8.9-5



## UNIT IX

### From Measurement to Mensuration

- 9.1 Length and its measure
- 9.2 Perimeter and its measure
- 9.3 Time and its measure
- 9.4 Money and its measure
- 9.5 Capacity and its measure
- 9.6 Mass (or weight) and its measure
- 9.7 Area and its measure
- 9.8 Formulae for areas of shapes
- 9.9 Volume and its measure
- 9.10 Formulae for volumes of solid shapes

9.1

#### A. Length and its measure

- B. There are objects which have lengths. Two lengths are either equal or one of them is greater than the other. Two lengths can be compared directly or indirectly through a unit common to both, though not constant from person to person. Any length can be taken as common unit; such an arbitrary unit remains the same from person to person. Standard units are universally accepted and they facilitate communication.
- C. Sticks of varying lengths; pieces of twine; span, cubit, match-sticks, pencils, wires; metric measures of length and metre scale.
- D. Sticks have lengths, pieces of thread have lengths and so on. Take two sticks, keeping them side by side such that one end of one is in level with one end of the other. Observe the other ends of the sticks and determine the longer. Take more than two sticks and arrange them according to length by direct comparison. Observe that if a stick A is longer than a stick B and the stick B is longer than a stick C, then the stick A is longer than the stick C (transitive property). To compare widths of objects which cannot be brought in proximity, say windows, measure the width of one with twine, bring that portion of the twine for comparison with the width of the other window and determine which window is wider. Or, use your span and find out how many spans roughly make the widths of the windows and from the numbers of spans, determine the wider window. To compare lengths of two long ropes, use your cubit. Observe that no two persons have spans and cubits of equal length. Choose an arbitrary unit, say match stick or unsharpened pencil and use either of them to compare widths of two benches. Observe that the measurement can

*Fig. 9.1-1*

be done in two ways. Arranging matches end to end, along the widths and finding roughly the number of matches needed to cover each of the widths is one way; the other way is to make use of one match stick a number of times by taking it along, stage by stage, while marking the end in each stage. *Fig. 9.1-2*

The standard measures of length in use are the metric unit of *metre* and its sub-units (*mm, cm, dm*) and super units (*dam, hm, km*). Observe that the maximum width of an adult male's palm is almost 10 cm or 1 dm. Observe that the width of the nail of a little finger of an adult male (or the width of the nail of a ring finger of an adult female) is almost 1 cm. Observe also that the thickness of the tip of a ball point pen is almost 1 mm. *Fig. 9.1-3 Fig. 9.1-4 Fig. 9.1-5*

Use a metre stick to find heights of children and lengths of classrooms. Take a piece of wire, measure its length, bend the wire to show up segments. Find the lengths of the segments and their sum. Observe that the length of the wire is the same as the sum of the lengths of the segments of the wire. (*conservation of length*)

Collect information about the length of your pace, your height; width round your neck, your chest expanded and chest normal, and your waist in cm (use measuring tape).

Collect information about the distance of your school, the nearest post office, the nearest bank, the nearest railway station and the nearest bus terminus from your home (use pedometer, if available).

Collect information about cloth requirements in metres for your clothes.

- E. Note that length, breadth, height, width, thickness, thinness, depth, etc. are all *lengths*. Children have trouble in reading the lengths on a graduated ruler by confusing intervals with marking; so special attention needs to be given.

## 9.2

### A. Perimetre and its measure

- B. Any closed plane shape has a boundary and the length of the boundary is the perimeter of the shape (e.g. polygon) which is the sum of the lengths of its edges. If the edges of a many-edged plane shape (i.e. polygon) are equal in length, the the perimeter of the shape is length of one edge multiplied by the number of edges. The perimeter of a triangle is the sum of its edges. The perimeter of a triangle having two edges equal (an isosceles traingle) is the sum of twice one of the equal edges together with the third edge. The perimeter of a triangle having three equal edges (an equilateral triangle) is thrice its edge. The perimeter of a rectangle is twice the sum of its length and width (or breadth). The perimeter of a square is four times the edge.

NON STANDARD MEASURES OF LENGTH



Span

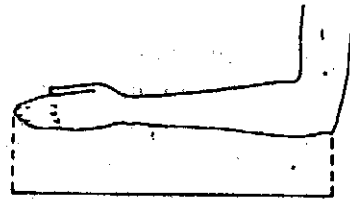

Cubit

Fig. 9.1-1

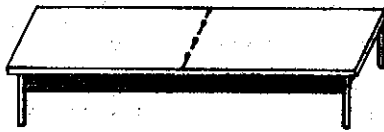

Width\_length by using  
match sticks



width\_length by using  
match sticks

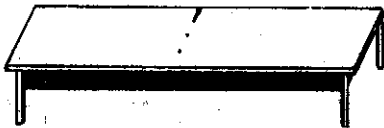

Width\_length by using  
a match stick

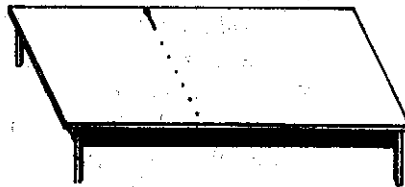

width\_length by using  
a match stick

Fig. 9.1-2

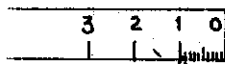

Ball point pen's tip  
.1 mm thick (approx)

Fig. 9.1-3

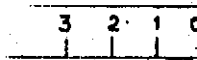

little finger  
tip width 1cm  
(approx)

Fig. 9.1-4

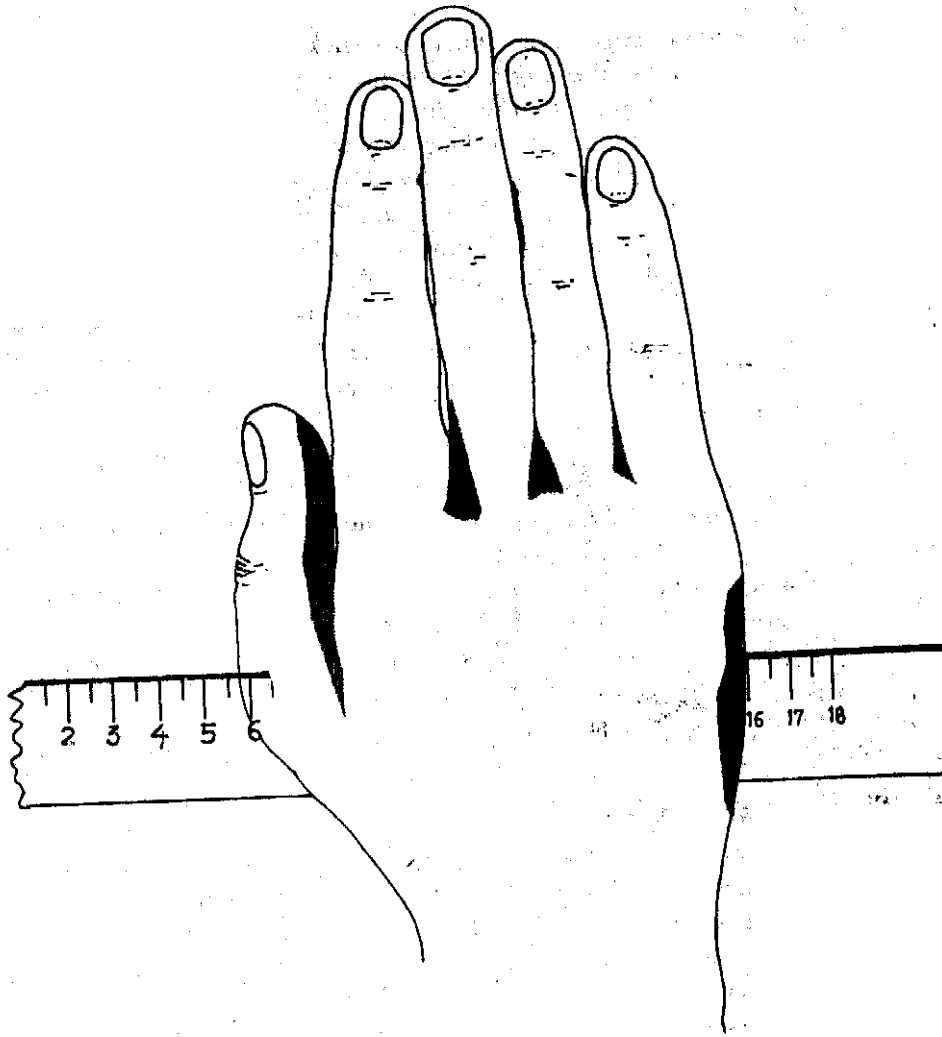

MAXIMUM WIDTH OF THE PALM OF  
AN ADULT MALE IS 10 cm OR 1 dm (Mode)

*Fig. 9.1-5*

**C. Sticks.**

**D.** Build a many-edged plane shape with sticks. Observe that its perimeter is the sum of the lengths of the sticks or edges. Build a rectangle with sticks. Observe that two different pairs of sticks of equal length are needed to build it and the perimeter of a rectangle is twice the sum of its length and breadth. Build a square with sticks. Observe that four sticks of equal length are needed to build it and the perimeter of a square is four times its edge.

Build a triangle with sticks. Observe that a triangle can be built with three sticks but not with *any* three sticks. *Only when the sum of lengths of two sticks is greater than the length of the third stick, the sticks can be used to build a triangle.* The perimeter of a triangle is the sum of the lengths of its three edges.

Build an isosceles triangle with two sticks of equal length and one other stick, while observing that the sticks should satisfy the condition for building a triangle. The perimeter of an isosceles triangle is the sum of twice the length of one of the two equal edges and the length of its third edge. Build an equilateral triangle with three sticks of equal length. Observe that three sticks of equal length always satisfy the condition for building a triangle and that the perimeter of an equilateral triangle is thrice the length of its edge.

**9.3**

**A. Time and its measure**

**B.** When two events happen at the same time, the two events, are said to take place at the same *instant*. When an event happens and after some time another event happens, then there is an *interval* of time between the two happenings. Time taken by the earth to go around the sun is one *year*.

Time taken by the earth to rotate about itself is one *day*. When you count one to sixty slowly, the interval or time taken is almost 60 seconds or 1 *minute*.

The hour hand (of an analogue clock) takes 12 hours to go round once, whereas the minute hand takes 1 hour to go round once.

The time or interval taken for the sun to appear at the same spot on the eastern horizon is 1 year. The time or interval taken for the moon in one phase to show the same phase is roughly 1 month. Also the time or interval between one new moon (or one full moon) and the next new moon (or the next full moon) is roughly 1 month.

**C.** A big ball and a small ball. Clock with hour hand and minute hand. Stop watch. A digital clock.

**D.** Two persons clap at the same time. Observe that this illustrates the instant aspect of time. One person claps. After sometime another person claps. Observe that this illustrates the interval aspect of time.

Keep the bigger ball stationary. Make the small ball rotate about itself and while doing so, take it round the bigger ball. Children also can enact this. Observe that this rough model illustrates earth's rotation about itself and around the sun, explaining how the intervals of a day and a year are conceived.

Keep record of the spot at which the sun is seen rising on the eastern horizon on a certain day and observe that almost after 1 year the sun is seen rising at the same spot on the eastern horizon. Keep record of the phase of a moon on a certain night and observe that the same phase of the moon appears almost after a month. Observe also that the interval between the occurrences of two new moons or two full moons is almost a month.

Count one to sixty slowly and observe that the interval taken is almost one minute or sixty seconds. Use a digital clock to verify and check. Take a working clock and set hands to show 12 o' clock, 2 hours 30 minutes, etc. Observe that at the instant of half an hour past an hour, the hour hand is half way between the mark of the hour gone and the mark of the hour to come and the minute hand is at 6 (or 30 minutes).

## 9.4

### A. Money and its measure

B. The denominations of Indian money are (1 paisa), (2 paisa), 5 paisa, 10 paise, 20 paisa, 25 paisa, 50 paisa, 1 rupee, 2 rupees and 5 rupees in *coinage* and 1 rupee, 2 rupees, 5 rupees, 10 rupees, 20 rupees, 50 rupees, 100 rupees and 500 rupees in *currency notes*. Money can be given in different denominations and their combinations. *Specifying coins indicates a certain money value, whereas specifying money value does not indicate any particular denomination.*

Coins can be counted by comparison of heights of coin-piles, having counted the number of coins in a pile.

C. Dummies of coins and notes of Indian currency and actual coins.

D. Two rupee coin can be given in only one way, whereas two rupee money can be given in different ways such as (1) 2 one rupee coins or notes (2) 1 one rupee coin or note and two 50 paise coins, (3) 1 one rupee coin or note and four 25 paise coins etc.

Pile 20 quarter rupee coins on a horizontal surface. Pile by its side quarter rupee coins to reach the same height. Observe that in the second pile the number of quarter rupee coins is twenty.

List articles which can be bought for the same amount of money not exceeding (1) one rupee and (2) five rupees.

### A. Capacity and its measure

- B.** Two containers have either equal capacity or one of them has greater capacity than the other. Two containers showing the same capacity may be different in height and width of mouth (*conservation of capacity*). Two containers can be compared directly or indirectly through a unit common to both, though not kept constant by all or varying from one person to another. Any container can be chosen arbitrarily as a common unit and kept constant by all. Standard units are universally accepted and they facilitate communication.
- C.** Coconut shells, handfuls, teaspoons, cups, empty ink-bottles, empty soda bottles, empty milk bottles, tins, buckets, plates, standard measures of capacity, litre, millilitre, etc., water, sand.
- D.** Take two buckets. Compare their capacities by taking water or sand in one to the brim and pouring the contents into the other without spilling. Observe that if the contents of the first are emptied in the process, and the second is also filled to the brim, the two containers have the same capacity. If on the other hand, the first container is yet to be emptied when the second is completely filled up, observe that the capacity of the first container is greater. Take more than two containers and arrange them according to capacities, by direct comparison. Observe that if a vessel A can hold more than a vessel B and the vessel B can hold more than a vessel C, then the vessel A can hold more than the vessel C (*transitive property*).

To compare capacities of two tins, measure the capacity of each with handfuls of sand or coconut shells of sand and find out which takes more handfuls or coconut shells of sand. Observe that all handfuls and coconut shells are not of equal measure in capacity.

Choose an arbitrary unit, say, milk bottle or soda bottle or ink-bottle. Use it to compare capacities of two containers. Observe that measuring can be done in two ways (1) pouring out the water of a container to fill up a number of soda bottles, milk bottles, or ink bottles and counting the number of bottles and (2) using a bottle a number of times and finding roughly the number of times the bottle is used to empty or fill up the container. Pick out two containers differing in height and width, but having the same capacity. (*conservation of capacity*)

Make a cubical hollow tin or card board container measuring 1 cm by 1 cm by 1 cm. Note that its capacity is 1 millilitre.

Make a cubical hollow tin or card board container measuring 10 cm by 10 cm by 10 cm. Note that its capacity is 1 litre.

Identify standard units of capacity measure, litre and its subunits (*ml, cl, dl*) and super units (*dal, hl, and kl*) and determine the capacities of familiar containers.

Observe that a teaspoonful is 5 millilitres. Collect information about the amount of water consumed and milk consumed by you in a day. Collect information about the capacities of flower pots, kitchen pots and containers of tin foods.

9.6

### A. Mass and its measure

**B.** Two objects have either equal mass (or weight) or one of them weighs more (has more mass) than the other. Two objects having the same mass may be different in shape and size (*conservation of mass*)

Two objects (liftable) can be directly compared by their pulling effect or indirectly through a unit common to both with the use of a balance.

The common unit need not be constant to all persons. Any object if need be can be chosen arbitrarily as a measure of mass and kept constant by all. Standard units are universally accepted constant measures of mass and they facilitate communication.

**C.** Buckets; tins and sand, stones, locks, marbles, bricks, nails, spring balance, scale balance, standard units of mass, *gram*, its subunits (*mg*, *cg*, *dg*) and superunits (*dag*, *cg*, *kg*).

**D.** Take two buckets of different capacities. Fill them partially with sand. Lift them separately in both the hands and determine the heavier or the lighter by their pulling effect. That which pulls more has greater mass. Take more than two stones varying widely in weight and arrange them according to their masses. Observe that if a stone A is heavier than a stone B and the stone B is heavier than a stone C, then the stone A is heavier than the stone C (*transitive property*)

To compare masses of two bricks or locks, use a scale pan. By putting them separately in the pans, observe which pan rests in lower position and decide that the object in that pan is heavier.

Measure out stones or marbles or nails to balance a brick or lock in weight. In comparing the numbers of nails required to balance two objects, observe that the object which is heavier requires more number of nails

Observe that all stones do not weigh equally but all nails of the same metal and number (or length) weigh equally. Pick out two objects of different shape but having the same mass through use of nails and scale balance (*conservation of mass*).

Identify standard units *gram*, its subunits (*mg*, *cg*, *dg*) and super units (*dag*, *hg*, *kg*) and use weights in vogue in the market. Use spring balance (calibrated in metric units) and find the weights of bundles of books and bundles of notebooks.



Observe that the mass (or weight) of 1 office clip is 1 gm. Verify by taking 1000 clips on one pan and 1 kg in the other pan of the scale balance, observing that the scales are even. Obtain information about your weight, weight of the load of books you carry, weight you can lift etc.

- E. Rough and incomplete ideas are accepted at this stage. Refinement and more complete ideas are postponed to higher classes.

## 9.7

### A. Area and its measure

- B. Two enclosed flat surfaces have either equal coverage of space or area or one of the surfaces is larger (has greater area).

Two surfaces having the same area may be different in shape (*conservation of area*).

Two surfaces can be directly compared in respect of area by placing one over the other or indirectly through a unit common to both. The common unit need not be constant for all persons.

Any (tessellating) shape can be chosen arbitrarily as a common measure of area and kept constant by all. Standard units such as *are* and *hectare* are universally accepted constant measures of area and they facilitate communication.

*Cm square* is different from a *square cm*, though they have the same area. *The shape of the first is known, whereas the latter can be in different shapes.*

- C. Leaves, papers, match labels, used stamps, paper squares, square ruled sheets plain and transparent, non-standard and standard ( $cm^2$  &  $mm^2$ ) units of area; *square metre (sq.m)* or  $m^2$ , *square centimetre*, are (100 *sq.m* or  $m^2$ ), *hectare (ha)* (100 *areas* or 10000 *sq. m* or  $m^2$ ).  
1 *sq. km* ( $km^2$ ) or (100 *ha* or 1000, 000 *sq.m* or  $m^2$ ).

- D. Take two leaves and place one over the other. One containing the other is larger (has greater area).

In cases when one leaf is not contained in the other with its portions protruding, cut off the protruding portions and see if the cut off portions can be accommodated in the spaces left in the other leaf. If this can be done, the containing leaf is larger in area. *Fig. 9.7-1*

Observe that half of a rectangle can be had in different ways and each way gives a different shape. But all the shapes have the same area.

Cut out from the square ruled sheet shapes having the same number of squares. Observe that a shape can be changed without change in its area.

*Fig. 9.7-2*

Take more than two leaves. Arrange them according to their areas. Observe that if a leaf A is larger than a leaf B in area, and if the leaf B

WHICH LEAF IS LARGER ?  
WHICH LEAF HAS GREATER AREA ?



Fig. 9.7-1

SAME AREA IN DIFFERENT SHAPES

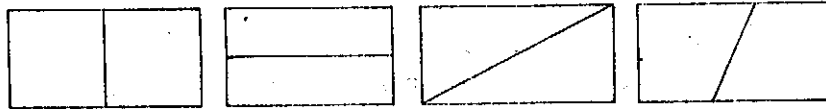

Halves of the same rectangle

Fig. 9.7-2

is larger than a leaf C in area, then the leaf A is larger than the leaf C in area (*transitive property*).

Take the surfaces of books and notebooks. Use match labels or used stamps (of the same size and shape) as units. To find and compare areas, observe that it can be done in two ways: (i) placing as many match labels (or used stamps) contiguously over the surfaces without leaving gaps and counting the number of match labels (or used stamps) required or the number of times a single match label (or used stamp) is to be used to cover the surfaces. The surface requiring more match labels (or used stamps) has greater area.

Draw two shapes at random. Place square ruled transparent sheet over them. Count the squares enclosed in each shape. The shape accommodating greater number of squares has larger area. Give the area in terms of squares. If the rulings are to make cm squares, give the area in sq cm or  $\text{cm}^2$ .

Use square slips of the same size to build rectangles and squares.

Observe that by counting the number of rows and number of squares in each row, the number of squares needed for construction of a rectangle or a square can be obtained by multiplying the two numbers. In other words, the area of a rectangle or a square is given by the product of two numbers, one representing the number of rows and the other the number of squares in each row.

9.8

### A. Formulae for areas of shapes

- B. The area in square units of a rectangle is given by the number of units in its length multiplied by the number of units in its width (or breadth)

$$A = l \times b.$$

The area in square units of a square is given by the square of the number of units in its edge.

$$A = a \times a \text{ or } a^2.$$

The area in square units of a right angled triangle is given by half the product of the number of units in the edges containing the right angle.

$$A = \frac{1}{2} a \times b.$$

The area in square units of a triangle is given by half the product of the number of units in the base and the number of units in the height of the base from its top (opposite) corner.

$$A = \frac{1}{2} b \times h.$$

- C. Unit squares and their parts, half unit squares, quarter unit squares  $\frac{1}{3}$  unit squares,  $\frac{1}{8}$  unit squares.

**D.** Build a rectangle with unit squares. Observe that the rectangle occupies as much space as the unit squares composing the rectangle. The number of unit squares covering a rectangle can be found by multiplying the number of rows and the number of squares in each row. The product of these two numbers gives the area of the rectangle in square units. Observe that the number of squares in each row (or the number of columns) is the same number of rows (or the number of squares in each column) is the same as the number of units in the breadth of the rectangle.

**Fig. 9.8-1**

Observe that the area of a rectangle can be given by the product of two numbers, one giving the number of units in length and the other giving the number of units in breadth. Note that the numbers are natural ones. Given the length and the breadth of a rectangle in fractional numbers, examine if this method holds true in finding the area of the rectangle. Use unit squares and their parts in building such a rectangle.

**Fig. 9.8-2**

One such rectangle built thus is shown above. The length of the rectangle is  $4\frac{1}{2}$  units and the breadth of the rectangle  $2\frac{1}{4}$  units. Observe that two rows of 4 unit squares each, 2 half unit squares, 4 quarter unit squares and one  $\frac{1}{8}$  unit square have been used. The space covered is equal to the space required by 10 unit squares and one  $\frac{1}{8}$  unit square. But  $10\frac{1}{8}$  is simply the product of  $4\frac{1}{2}$  and  $2\frac{1}{4}$ . So the area of a rectangle can be given by the product of the number of units (whole or fractional) in length and the number of units (whole or fractional) in breadth. In symbols  $A = l \times b$ .

Build squares with unit squares and then build squares with unit squares and their parts. Observe that the area of a square can be obtained by squaring the number of units in (the length of) its edge, showing that the experience is the same as in the case of building rectangles with unit squares and unit squares and their parts.

Take a paper rectangle. Take half of it forming a right angled triangle. With a transparent square ruled sheet placed on it, count the squares in the rectangle and in the right angled triangle. Observe that the number of squares composing the right angled triangle is half the number of squares composing the rectangle.

The length and the breadth of a rectangle are related to the edges containing the right angle in the right angled triangle (got by cutting along a diagonal of the rectangle). So the formula for the area of the right angled triangle is half the product of the numbers of units in the (lengths of) edges containing the right angle. In symbols

$$A = \frac{1}{2}ab \text{ (a, b edges).} \quad \text{Fig. 9.9.3}$$

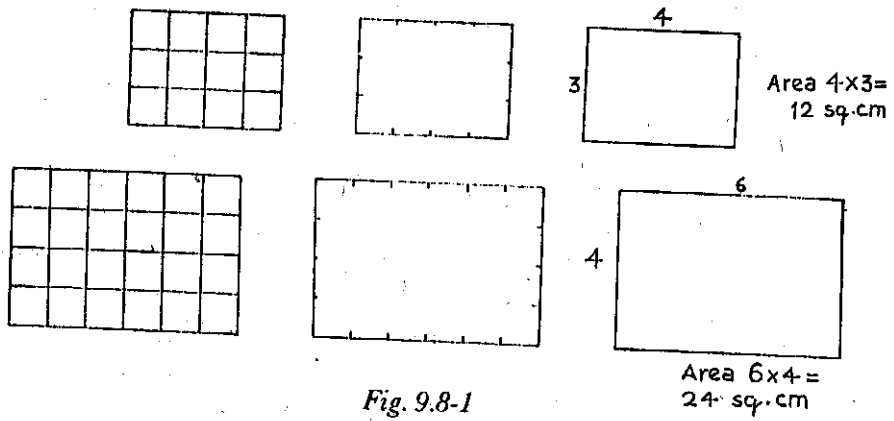
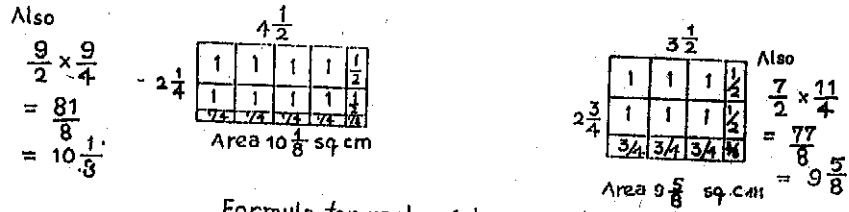

Fig. 9.8-1



Formula for rectangular area step by step

Fig. 9.8-2

### AREA OF TRIANGLE

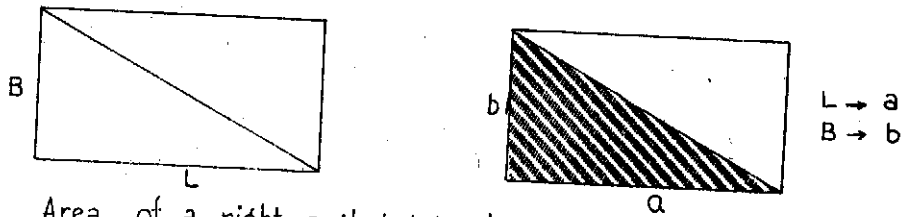

Area of a right angled triangle =  $\frac{1}{2}$  the area of the rectangle  
 $= \frac{1}{2} \times L \times B = \frac{1}{2} \times a \times b = \frac{1}{2}$  the product of sides containing the right angle

Fig. 9.8-3

Take a paper rectangle. Keep one edge as base and take a point on the opposite edge and join the point to the ends or corners of the base edge. A triangle is formed and it is acute angled. Fold the paper rectangle breadthwise through the point (on the length) and observe that the crease makes right angles with the base edge and hence becomes the height of the triangle. Unfold and observe that the triangle is composed of two right angled triangles, each of which is half of the corresponding rectangular portion.

**Fig. 9.8-4**

Observe that the (area of the) triangle is the sum of (the areas of) two right angled triangles which is the same as the sum of the halves of the (areas of) two rectangular portions. Observing that sum of halves of the parts making a whole is the same as half of the whole, the area of the triangle is half of the area of the rectangle. So in symbols the area of a triangle is given by

$$\frac{1}{2} b \times h. \quad (b = \text{base}, h = \text{height})$$

If a point taken in the opposite edge is outside the lengths of the rectangles and the point is joined to the ends or corners of the base of the rectangle, an obtuse angled triangle is formed. As before, fold the paper breadth wise at the point (on line having the length wise edge) Expand the base line (or bottom length) by folding along it. Observe that the height falls outside the triangle and that the area of the obtuse angled triangle is half of the *difference* of areas of the bigger rectangle and the smaller rectangle formed. So in symbols, the area of a triangle, acute or obtuse or right angled is

$$\frac{1}{2} b \times h. \quad \text{Fig. 9.8-5}$$

In a right angled triangle, notice that one of the sides containing the right angle becomes the height when the other is taken as base.

- E. Precision is avoided to gain initial familiarity with the concept of area through experience.

**Fig. 9.8-6**

9.9

### A. Volume and its measure

- B. Two blocks have either equal volumes or one of them has greater volume than the other. Two blocks having the same volume may be different in shape (*conservation of volume*)

(Two solids objects can be compared in respect of their volumes by immersing them in turn in a trough of water and comparing the rises in the level of water from initial level in the trough -*from Physics*)

(*The capacity of a hollow solid or container is the volume of its content*)

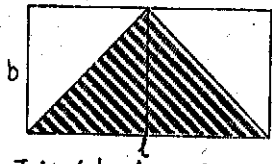

Triangular Area =  $\frac{1}{2} \ell b$   
 $= \frac{1}{2} b_1 h + \frac{1}{2} b_2 h$   
 $= \frac{1}{2} (b_1 + b_2) h = \frac{1}{2} bh$

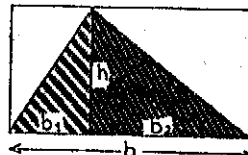

Area of a triangle (acute)  
 $=$  Sum of areas of two right angled triangles.

$\ell \rightarrow b = b_1 + b_2$   
 $b \rightarrow h$

Fig. 9.8-4

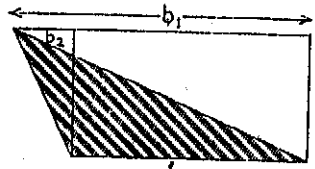

Triangle area =  $\frac{1}{2} \ell b$   
 $= \frac{1}{2} b_1 h - \frac{1}{2} b_2 h$   
 $= \frac{1}{2} (b_1 - b_2) h = \frac{1}{2} bh$

Area of a triangle

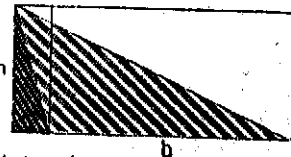

= Difference of areas of two right angled triangles.

$\ell \rightarrow b = b_1 - b_2$   
 $b \rightarrow h$   
 Area of a triangle (obtuse)

Fig. 9.8-5

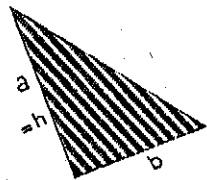

Area of a right angled triangle  
 $= \frac{1}{2} bh$   
 $= \frac{1}{2} ba$   
 $= \frac{1}{2}$  the product of sides containing the right angle

Fig. 9.8-6

The standard metric units of volume are *cubic cm or cm<sup>3</sup>*, *cubic metre or m<sup>3</sup>* (or *stere* for fire wood) and cubic *cubic km or km<sup>3</sup>*.

A *cm cube* is different from a *cubic cm*; the former has shape, whereas the latter has no particular shape.

- C. Cubes of the same size ( $\frac{3}{4}$  inch edge), cm cubes, plasticine or clay 10cm  $\times$  10cm  $\times$  10cm cubical container, granite stones (liftable).
- D. With as many cubes as may be required, build a block (cuboid or cube).

Observe the number of layers, the number of rows in each layer and the number of cubes in each row. Observe that the number of cubes composing the block is simply the product of the three numbers.

*Fig. 9.9-1*

Jumble up the cubes making the block and rebuild the block in another way to take a different shape. Take some cubes at random, twice without counting, and build two blocks and compare their volumes. Observe that sometimes one block has the same volume as the other and that sometimes one block is bigger (has greater volume) than the other.

(Set up a trough with enough water. Take two solid objects which do not absorb water. Put them in turns and in each turn note the rise in water level. *The object that causes greater rise in water level has greater volume.* Observe that if an object A has greater volume than an object B and the object B has greater volume than an object C, then the object A has greater volume than the object C. (*transitive property*).

By comparing rises in water level, arrange three or more granite stones according to their volume).

Use a certain quantity of plasticine (or clay). Make it into an object having some shape. Change the shape in different ways and observe that the volume each time remains the same (*conservation of volume*).

If a block is built with cubes, the volume of the block is in *cubic cm or cm<sup>3</sup>*.

Obtain information about the number of beans and the number of paddy or wheat grains that can be contained in a container of capacity 1cm<sup>3</sup> or 1 millilitre.

- E. Common or arbitrary units do not get as much importance in volumetric measure as in other measures.

## 9.10

### A. Formulae for volumes of solid shapes

- B. The volume of a cuboid in cubic units is the product of the number of units in *length*, the number of units in *width* (or *breadth*) and the number of units in *height*.

In symbols  $V = l \times b \times h$  ( $l$  = the number of units in length,  $b$  = the



BUILDING A BLOCK WITH UNIT CUBES

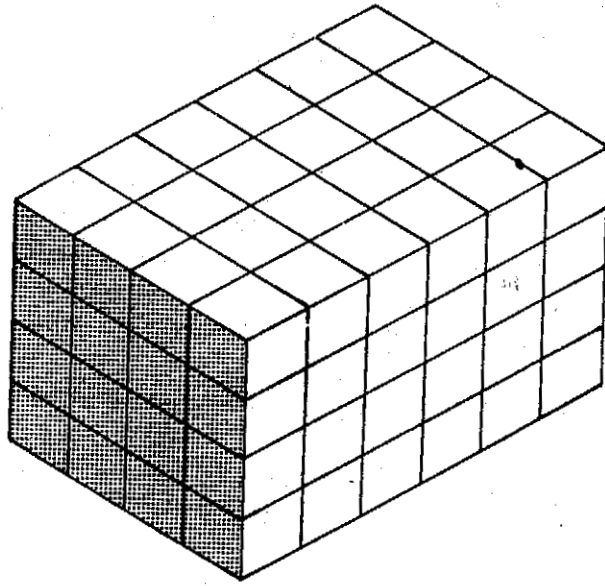

Number of Cubes = Number of Layers  
X Number of Rows  
X Number of Cubes in each row

*Fig. 9.9-1*

number of units in width,  $h$  = the number of units in height).  
 The volume of a cube in cubic units is the cube of the number of units in its edge.

In symbols,

$$V = a \times a \times a \text{ or } a^3 \text{ (} a \text{ - the number of units in an edge).}$$

**C.** Inch cubes and parts of inch cubes in halves, quarters, thirds and eighths.

**D.** Build a block with inch cubes. Observe that the number of cubes composing the block is the product of the number of units in length, the number of units in width and the number of units in height. Observe also that (1) the height of the block is given by the number of layers of cubes, (2) the width by the number of rows of cubes in each layer and (3) the length by the number of cubes in each row. So the volume of a cuboid can be given by the product of the number of units in length, the number of units in width and the number of units in height, (all the numbers here being natural).

Build a block with inch cubes and their parts. Let the edges measure  $3\frac{2}{3}$  by  $2\frac{1}{4}$  by  $1\frac{1}{3}$ . Count the cubes and observe that the volume is

given by the product of the number of units in length, the number of units in width and the number of units in height, (the numbers here being fractional)

Build a block with inch cubes and then with inch cubes and their parts such that the number of layers of cubes = the number of rows of cubes in each layer = the number of cubes in each row. The block built is a cube. Count the number of cubes composing the cubical block and observe that the volume is easily got by cubing the number of units (fractional or natural) in its edge. In symbols

$$V = a \times a \times a \text{ or } a^3 \text{ (} a \text{ - the number of units in an edge).}$$

## Bibliography

1. Wahl, John & Stacy, (1976), *I can Count the Petals of a Flower*, NCTM, U.S.A.
2. CEDO, (1971), *Mathematics Apparatus For Primary Schools*, Heinemann, U.K.
3. Botterill D, and Gaje M., (1974), *Early Learning and Thinking in Mathematics—Invicta Plastics*, U.K.
4. Bradshaw, M.F., (1974), *Logic Blocks in the Junior School*, E.S.A. Creative Learning Ltd., U.S.A.
5. Wells, P (Ed.), (1972), *Rods, Blocks and Balances*, Association of Teachers of Mathematics, U.K.
6. Osurivoid, (1972), *Centicubes—A Teachers' Guide*
7. Stone, R.J., (1974), *Multi-Link Mathematics Cubes*, E.S.A. Creative Learning Ltd., U.S.A.
8. Sauvy, Jean & Simonne (1974) *The Child's Discovery of Space*, Penguin, U.K.
9. Berger, Emil J. (Ed.), (1973) *Instructional Aids in Mathematics (34th year book)*—NCTM, U.S.A.
10. Payne, Joseph N. (Ed.), (1975) *Mathematics Learning in Early Childhood (37th year book)*—NCTM, U.S.A.
11. Baratta—Lorton, Mary, (1972) *Workjobs*, Addison Wesley, USA
12. Baratta—Lorton, Mary, (1966) *An Activity Centered Mathematics Program for Early Childhood Education*, Addison Wesley, USA
13. Whitney, Hassler, (1974), *Elementary Mathematics Activities—Part A—Trial Materials*, Institute for Advanced Study, Princeton, USA
14. Turner, Ethel M, (1966), *Teaching Aids for Elementary Mathematics*, Holt, Rinehart and Winston, USA
15. Dienes Z.P., (1973), *Mathematics through the senses, games, dance, and art*, NFER Publishing Co. Ltd., UK
16. Sobel, Max A and Maletsky Evan H, (1975)—*Teaching Mathematics—A Source Book of Aids, Activities and Strategies*, Prentice Hall, USA
17. Hooten B, J.R. Jr and Mahaffey, M.L. (1973) *Ele, Maths Laboratory Experiences*, Merrill, USA
18. Raab, J.A. (1976) *Audio Visual Aids in Mathematics*, NCTM, USA
19. Nuffield/CEDO (1970) *Mathematics: the First 3 years*, Chambers, UK
20. Nuffield/CEDO (1972) *Mathematics: the Later Primary years*, Chambers, UK
21. Lumb D and Papendick A. (1978) *Mathematics 5-9*, John Murray, UK
22. Schools Council, (1972)—*Mathematics in Primary Schools—HMO (Her Majesty's Stationery Office)* UK.
23. Holt M and Dienes, Z.P. (1973) *Let's Play Mathematics*, Penguin, UK
24. Repyev, Alexander (1963) *Let's Play Geometry*, Mir Publishers, USSR
25. Dienes and Golding—*First year in Mathematics:*  
 I (1971) *Learning Logic, Logical Games*  
 II (1971) *Sets, Numbers and Powers*  
 III (1972) *Exploration of Space and Practical Measurement—ESA (Educational Supply Association)*, UK
26. Dienes Z.P. (1964) *Mathematics in the Primary School*, Macmillan, UK
27. Dienes Z.P., (1960), *Building up Mathematics—Hutchinson Educational*, UK
28. Dienes Z.P. and Jeeves M.A., (1965), *Thinking in Structures*, Hutchinson Educational, UK
29. Skemp R.R., (1971), *The Psychology of Learning Mathematics*, Penguin, U.K.
30. Sawyer, W.W., (1964), *Vision in Elementary Mathematics*, Penguin, U.K.

31. Srinivasan P.K., (1974), New Wave Primary Mathematics Books O(A), O(S) and I, Macmillan (India)
32. Srinivasan P.K., (1974), Teachers' Handbooks for New Wave Primary Mathematics Books O(A), O(B) and I, Macmillan (India)
33. Williams E. and Shuard M., (1976), Primary Mathematics Today, New Metric Edition, Longman, UK
34. Paige, D.D. Thiesseu, D; Wild, M: (1982) Elementary Mathematical Methods, John Wiley, USA
35. Wain G.T. Woodrow D (1980) Mathematics Teacher Educational Project with Students Material, Blackie, U.K.
36. Weissglass, J (1979)—Exploring Elementary Mathematics—Freeman, USA
37. Mathematical Association, UK (1970): Primary Mathematics—a Further Report
38. Unesco Institute of Education, (1976),—Mathematics in Primary Education (learning of maths by young children)
39. Downes W. & Paling D., (1970), The Teaching of Arithmetic in Tropical Primary School, Oxford, U.K.
40. Mathematics Counts—Cockcraft's Report, (1982) HMO (Her Majesty's Stationery Office), U.K.
41. Gibbons, R.P. and Blofield, B.A., (1971), Life Size. Macmillan, U.K.